

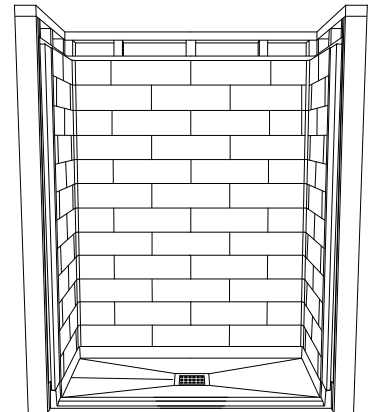

BY ACCESSIBILITY PROFESSIONALS

INSTALLATION INSTRUCTIONS

FOR SHOWER WALLS INSTALLATION

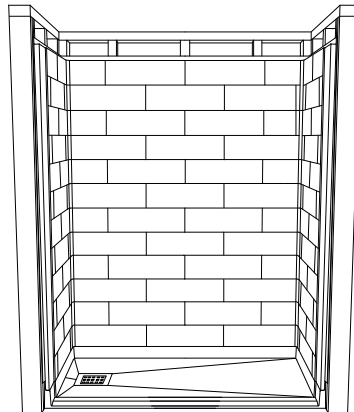
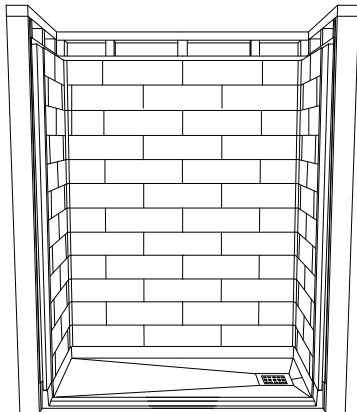
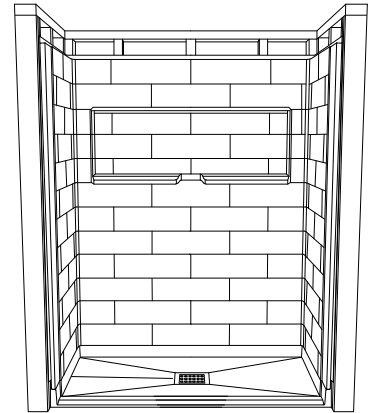
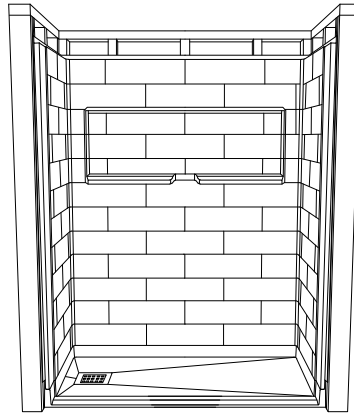
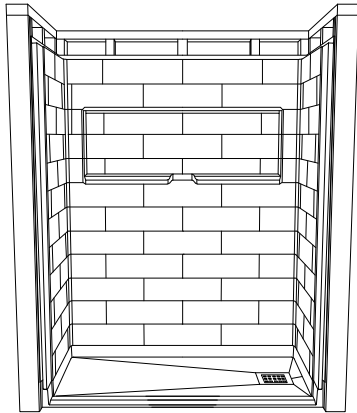

Prior to installation the shower must be checked thoroughly for defects. In the unlikely event that the product has a defect, it must not be installed. The manufacturer will not be held responsible for cost of removal or replacement of a shower and or walls or any other costs incurred as a result of the shower having a defect if the defect is identifiable prior to installation. **INSTALLATION OF THE SHOWER WILL BE TREATED AS ACCEPTANCE OF QUALITY.**

It is installers responsibility to ensure proper installation, a trouble-free water evacuation, and a total water tightness. **CHECK THAT SHOWER DRAINS PROPERLY. IF IN DOUBT, CONTACT YOUR SUPPLIER.** Drillings, and perforations are not covered by the warranty. They are under installers responsibility. The floor structure must be strong enough to support the weight of the shower unit in use.

Read all instructions carefully before proceeding.

SAVE THIS GUIDE FOR FUTURE REFERENCE.

IMPORTANT • Record the serial number



Serial number: _____

PARTS AND COMPONENTS

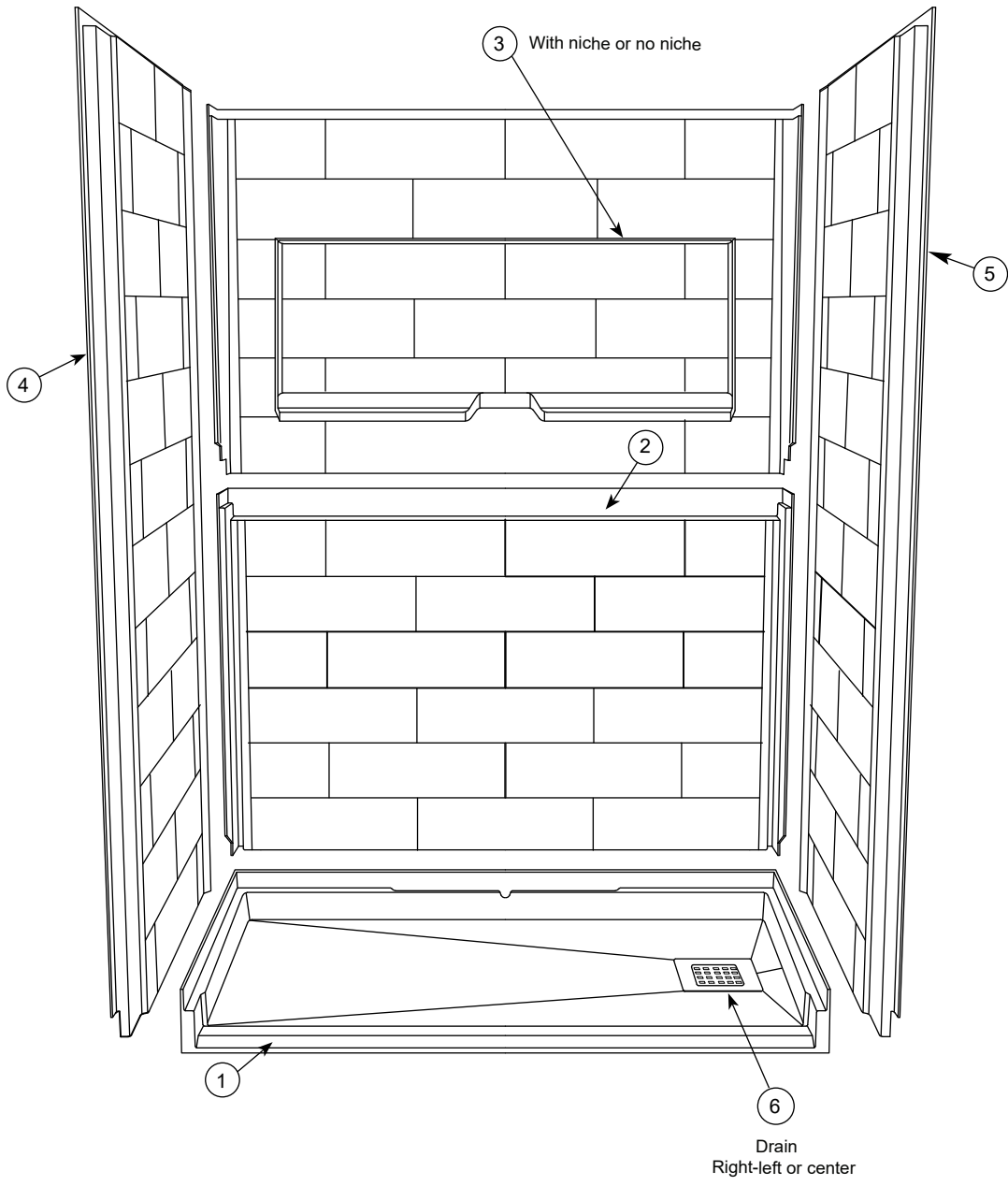

#	Part	Qt cant.
1	Base	1
2	Lower back wall	1
3	Upper back wall	1
4	Left side wall	1
5	Right side wall	1
6	Drain	1

TOOLS REQUIRED

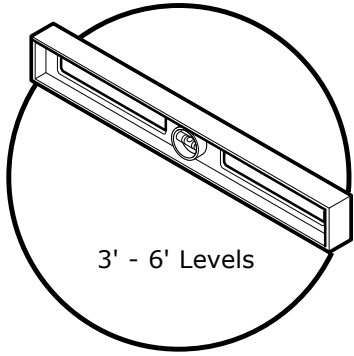

3' - 6' Levels

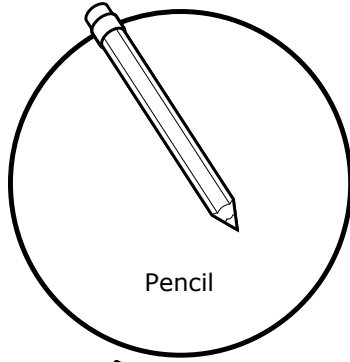

Pencil

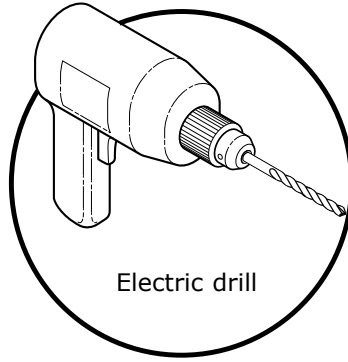

Electric drill

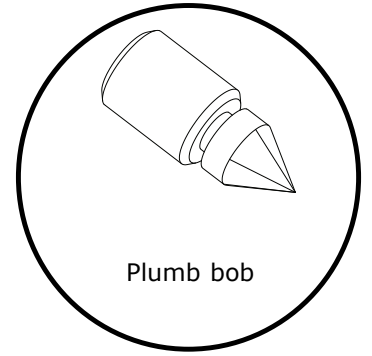

Plumb bob

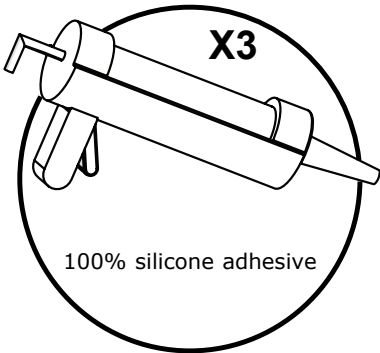

100% silicone adhesive

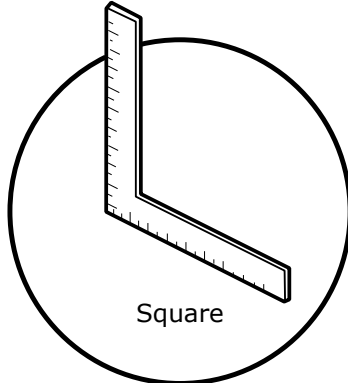

Square



12" Plumbers Level

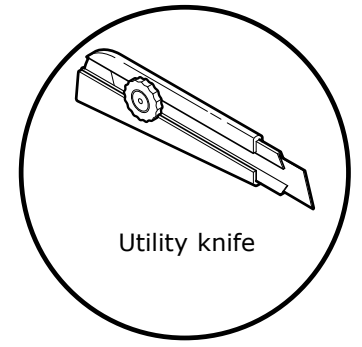

Utility knife



Security equipment

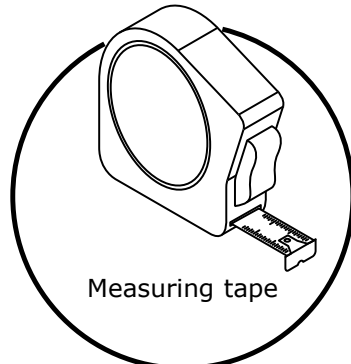

Measuring tape

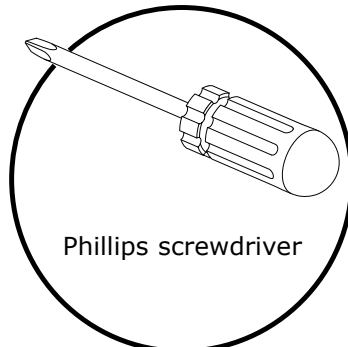

Phillips screwdriver

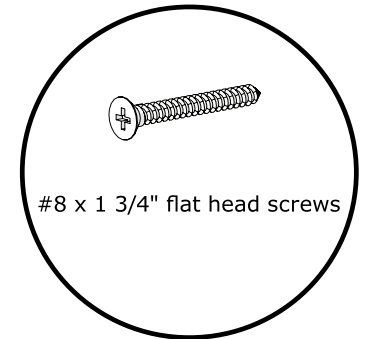

#8 x 1 3/4" flat head screws

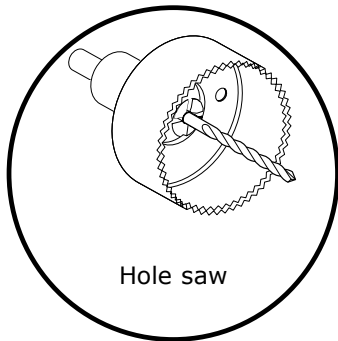

Hole saw

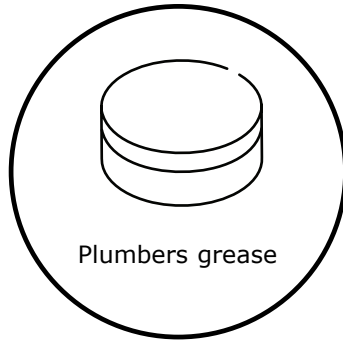

Plumbers grease

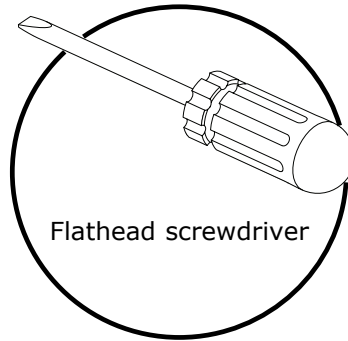

Flathead screwdriver

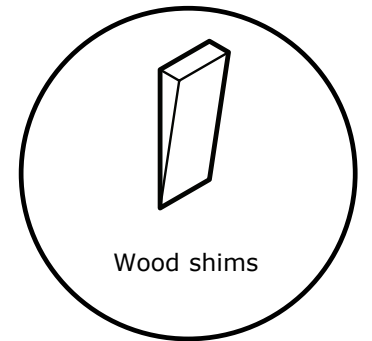

Wood shims

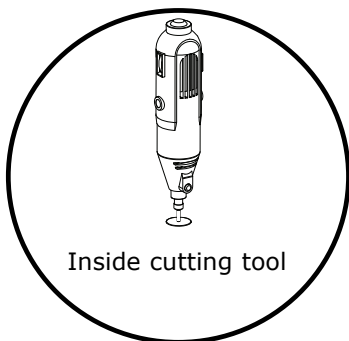

Inside cutting tool

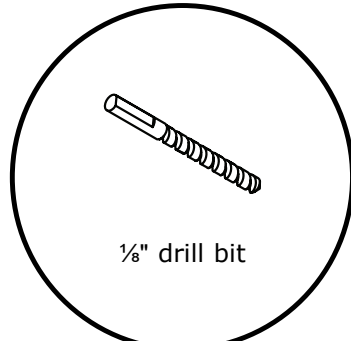

1/8" drill bit



Thin Set Mortar

Recommended for un-level sub floor of more than 1/8"

BEFORE YOU BEGIN

A. Before Starting make sure to have all parts and components, refer to page 2.

A. NOTE: If the installation area has a window present, please refer to page 18 of this guide for installation information.



FINAL VISUAL INSPECTION

Note: Not doing so could void your warranty

Prior to completing the installation, perform a visual inspection. If defects are visible, INTERRUPT THE INSTALLATION and communicate with our customer service: 877-947-7769.



1 Person Installation
Drain Included

B. Dry fit the wall set panel. This is important to confirm that:

- a) The correct panels have been received,
- b) The correct drain location,
- c) The panels are assembled prior to installing in the shower.

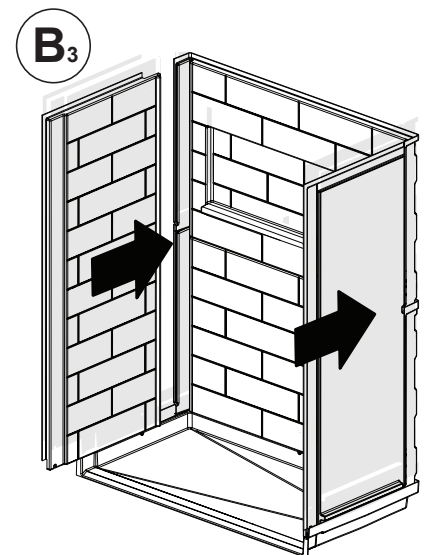
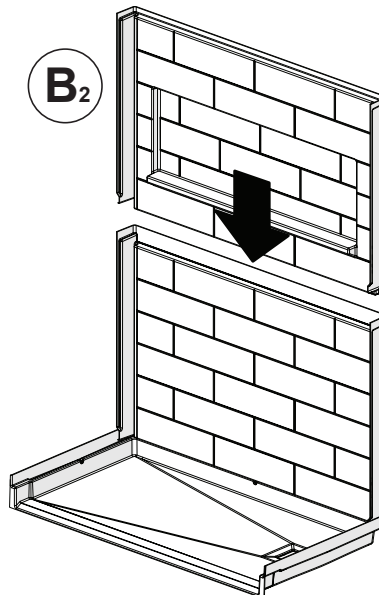
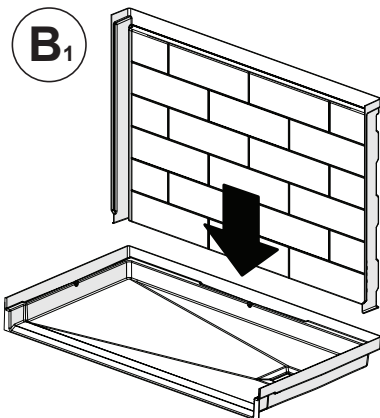

1

A. Build a structure based on the dimensions in the chart below. IF STRUCTURE IS ALREADY BUILT CHECK THAT IT RESPECTS THE DIMENSIONS BELOW.

Modelo	No.	A	B	C	D
APX6032BFKTL	xxxxxx	Between 60"- 60 1/4"	33" min.	15"	8 1/2"
APX6032BFKTR	xxxxxx	Between 60"- 60 1/4"	33" min.	15"	8 1/2"
APX6036BFKTL	xxxxxx	Between 60"- 60 1/4"	37" min.	17"	8 1/2"
APX6036BFKTR	xxxxxx	Between 60"- 60 1/4"	37" min.	17"	8 1/2"
APX6036BFKTC	xxxxxx	Between 60"- 60 1/4"	37" min.	17"	30"

A Top view of structure

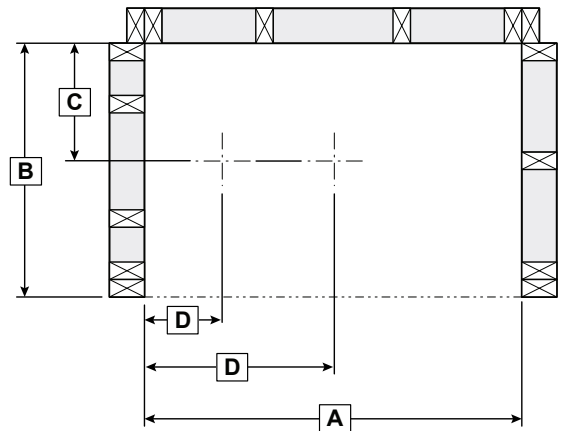

A. Plan stud layout to provide space for control valve and water outlets.

B. Verify the wall studs are square, plumb and the flooring is perfectly level.



Assembly of unit highly dependent on back wall studs being plumb. As little as 1/8" out of plumb to to bottom will misalign wall panels.

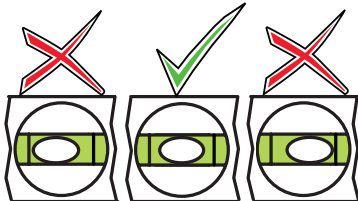

Leveling the floor is critical for a properly aligned installation. Auto-Leveling, rapid thin-set mortar can be used to level the floor. Be careful not to block the drain hole position.

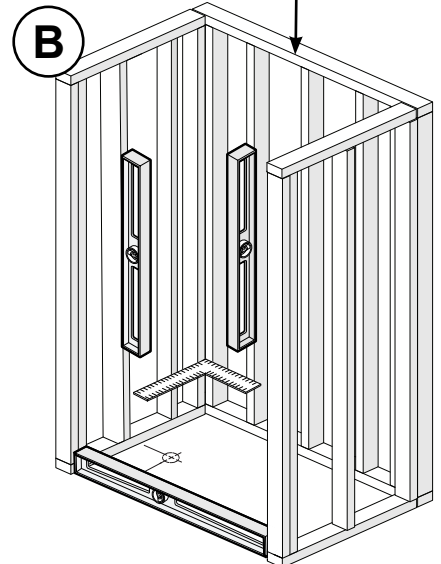

1

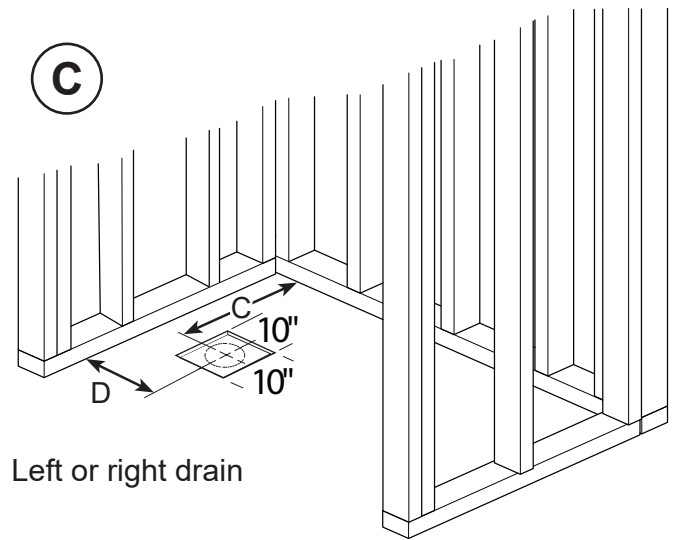

Left or right drain



Cut-Away Drain Core Detail-Concrete Slab

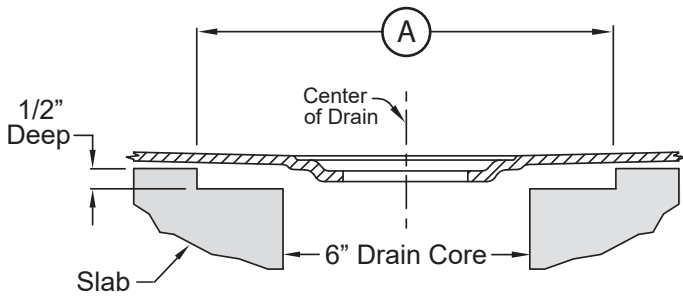

- (A) 10" x 10" x 1/2" Deep Recess (end drain)
- 12" x 12" x 1/2" Deep Recess (center drain)

C. Cut out drain opening in floor. For wood floors cut out a 10" x 10" opening around the drain through the floor. **NOTE:** For center drain units, this opening must be 12" x 12" through the floor.

When installing on a concrete slab, the drain core through the slab must be at least 6 inches diameter with a minimum 10" x 10" x 1/2" deep recess for end drain units -or- 12" x 12" x 1/2" deep recess for center drain units into the surface of the slab.

See images at the top, bottom and to the side for details of these openings.

Locate drain opening by following measurements C and D on the images and the chart on step 1.a. (shown on page 5).

We recommend that a plumber completes the drain pipe connection.

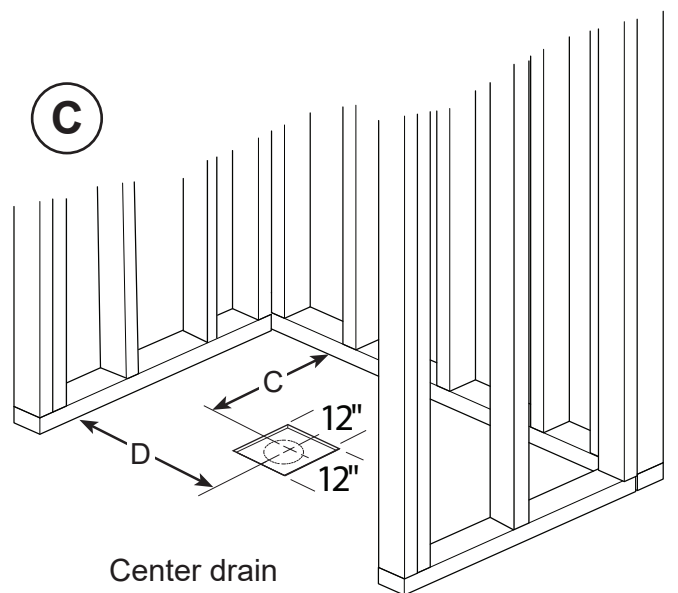

Center drain



Clean the alcove floor of all debris. Not doing so might affect the draft to drain.

2

A. Dry fit the base using a 3' level along all sides as shown. Check and adjust level side to side and front to back. Use 12" plumbers level to check the fall or slope to the drain from all sides as shown in A2.

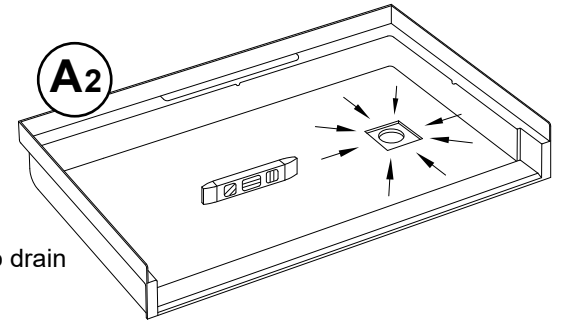
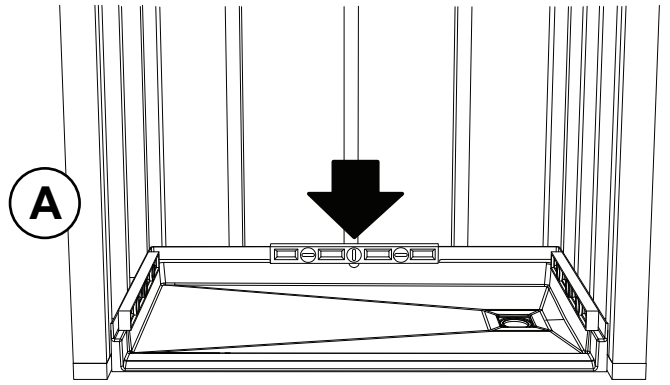

Check Slope to drain

Base can be shimmed up to 1/8". If it is more than 1/8" out of level, leveling cement is required. Rapid Cure latex modified thin-set tile mortar is recommended.

B. Mark the position of the base on floor and on the studs. Remove the base from the shower.

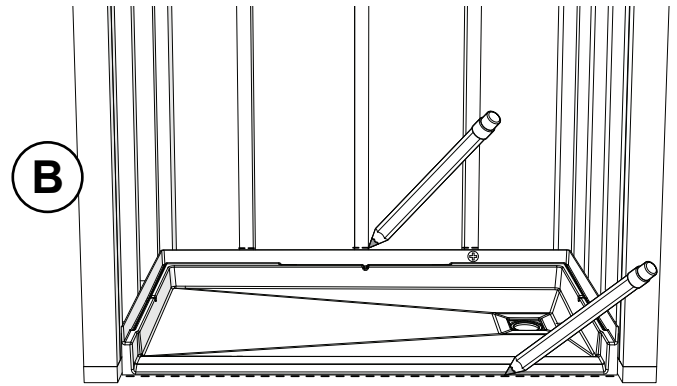

C. Apply a 1/8" width silicone bead around the edge of the drain hole in the base (surface between the top part of the drain and the base). Assemble as shown.

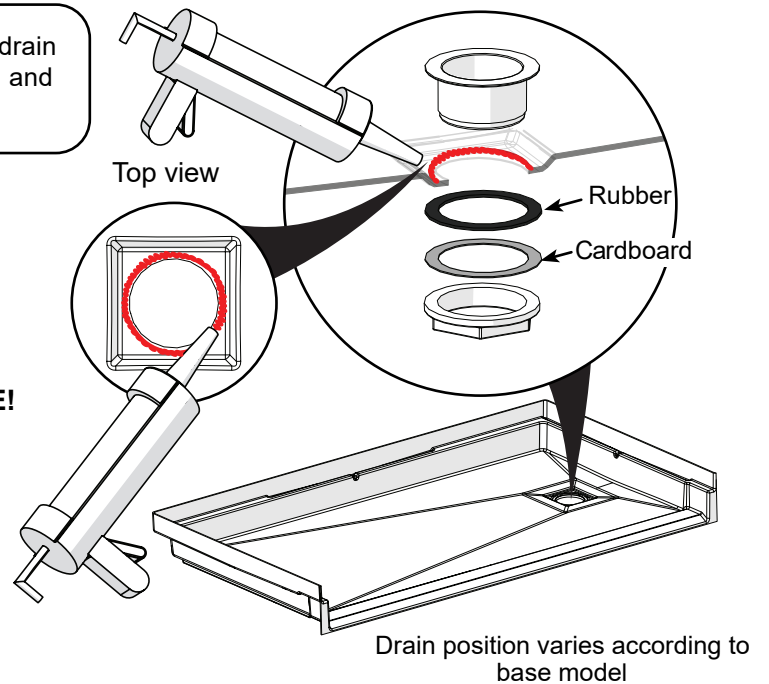

HAND TIGHTEN ONLY! REMOVE EXCESS SILICONE!

D. Use 3 tubes of 100% silicone adhesive in a squared pattern as shown. The adhesive should be applied in a height that ensures contact with the base as it sets in place which means each bead should be 3/4" or greater.

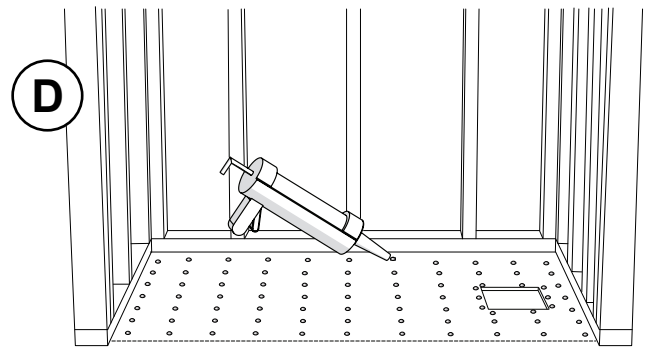

Each bead should be 3/4" or bigger.

E. Put back the base in the previously marked position.

Check that floor of shower is sloped towards drain. Use a 12" level and check for fall or slope from all sides as shown in E. This will be the LAST CHECK. Do not proceed until slope is confirmed or warranty will be voided.

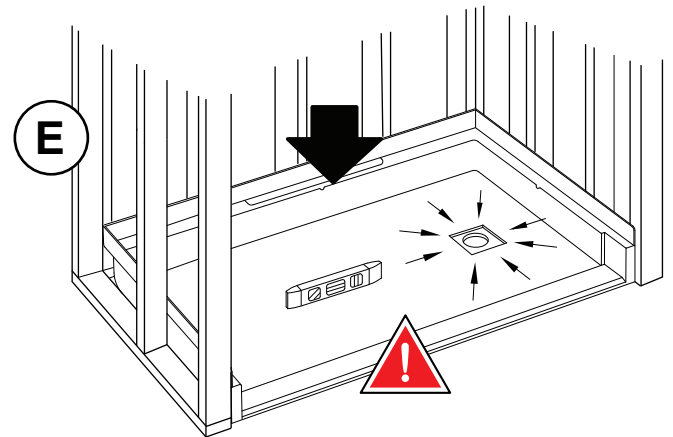

F. If needed use wood shims between the studs and the fastening flange to maintain centered position of base and avoid distortion of the flange. With a 1/8" drill bit, drill holes in the base flange then secure the base to all the wall studs with #8 x 1 3/4" flat head screws (not included). Pre-Drill the flange and not the studs. **HAND TIGHTEN ONLY!** THE CENTER OF EACH HOLE IN THE FLANGE MUST BE AT LEAST 41MM (1 5/8") FROM THE DECK OF THE BASE! FILL IN THE HOLES WITH SILICONE BEFORE INSTALLING SCREWS. CUT OFF THE EXCESS OF THE SHIMS.

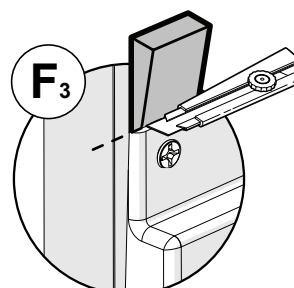
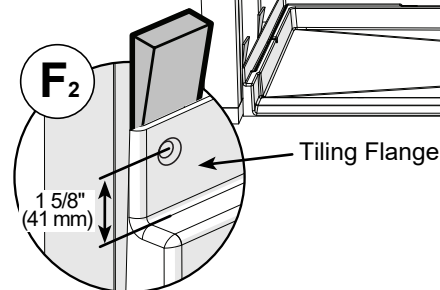
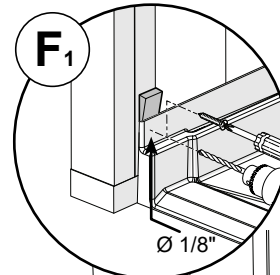

It is essential to properly center the base to ensure proper installation of the side walls.

G. Cut the drain pipe even with the top of the rubber gasket using an inside cutting tool.

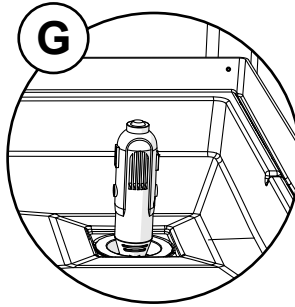

H. Using plumbers grease, lubricate the inside of the rubber gasket and slide over the drain pipe with bevel edge facing up. Push down until it sets itself.

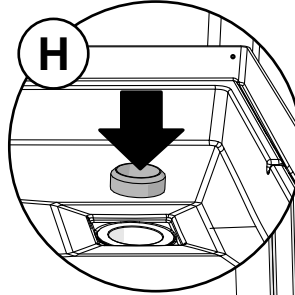

I. Screw compression ring into place until tight.

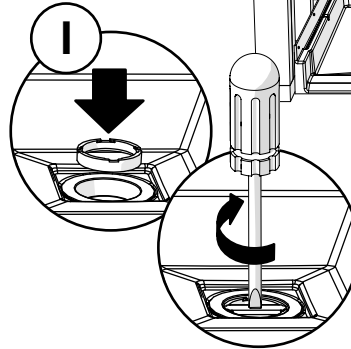

J. Snap the grid plate into place.

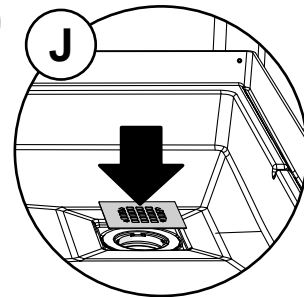

Bracing option (preferred)

K. To secure the base while the silicone cures there are two possible methods: Bracing (preferred): Brace the unit as close to the drain as shown. A properly braced threshold will result in flush contact to the subfloor along the entire threshold. Leave braces in place for 4 hours. Remove the braces and check draft and slope to the drain one last time.

Weighted option (alternate): When bracing is not possible, an alternate method is to weight down the base with 5 gallon buckets filled with water. After 4 hours remove the buckets and check the draft and slope to the drain.

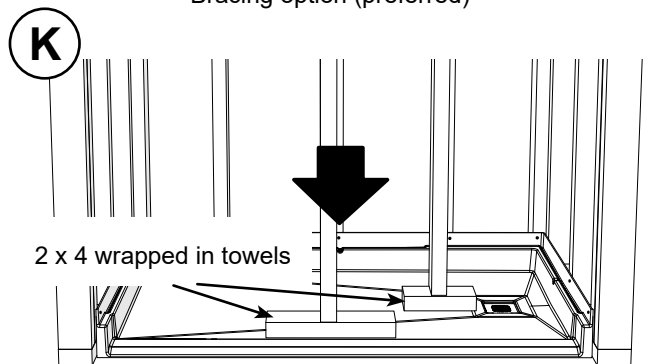

Weight option (alternate)

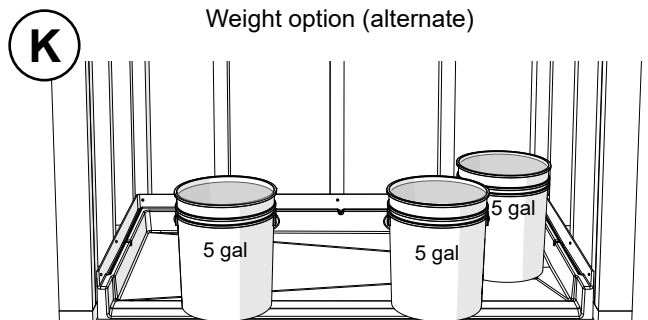

3

A. Insert the bottom back wall (#2) on the deck of the base. Use the key to find ideal position. Level vertically. Add shims as needed.

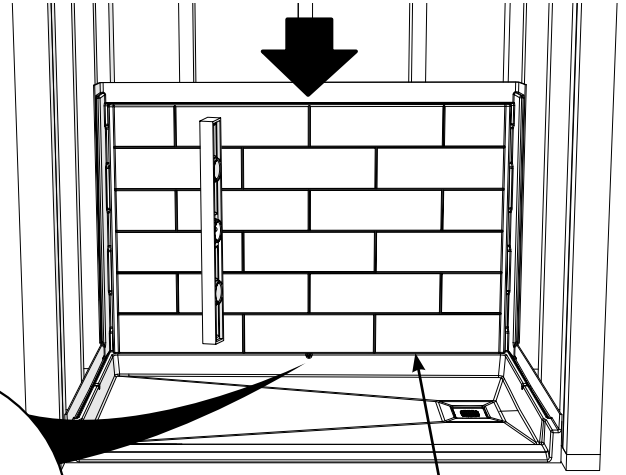

Plumb the lower back wall, shim if necessary.

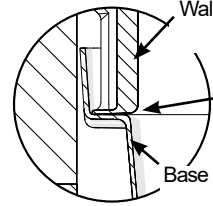
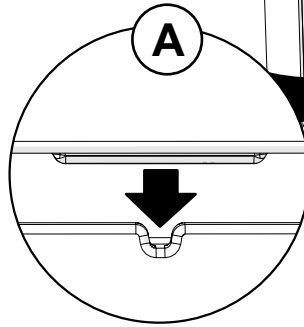

Overhang for watertightness.

B. Add shims as needed. Drill the flange and screw with the screws and a screwdriver, 3/8" from the top of the flange. Cut shim excess.

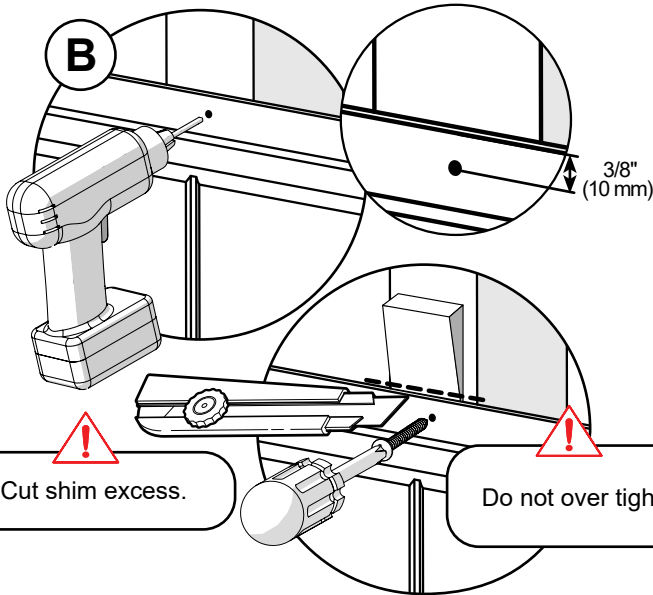

Cut shim excess.



Do not over tight.

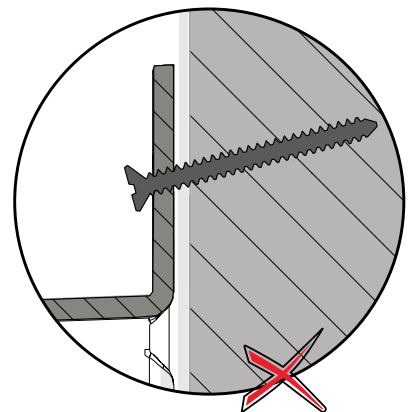
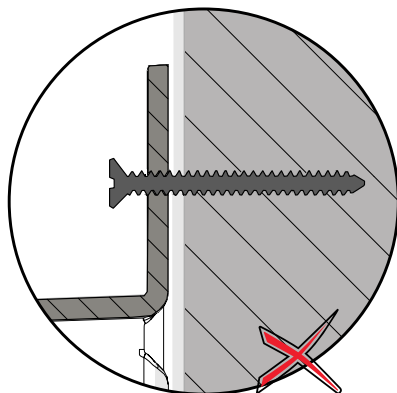
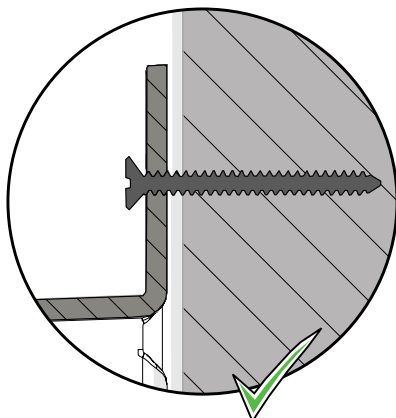
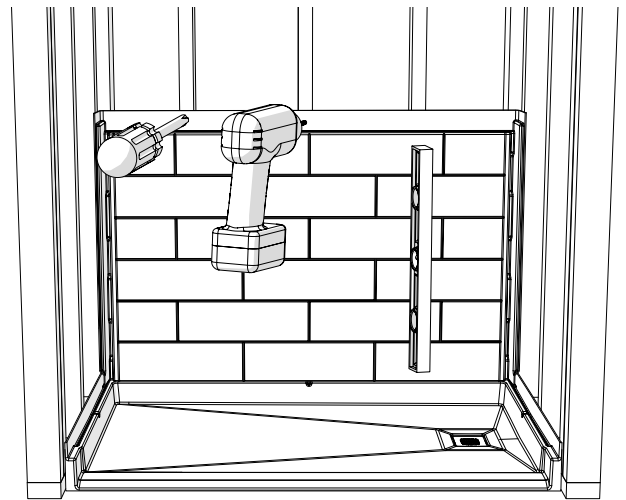

4

A. Insert the upper back wall (#3) on the top of the lower back wall (#2) aligning the attachment system between the two walls. Level vertically. Add shims as needed.

NOTE: The surface of the top wall and the bottom wall should be aligned at the same level.

Use the level next to the niche, not on the niche as shown in diagram A.

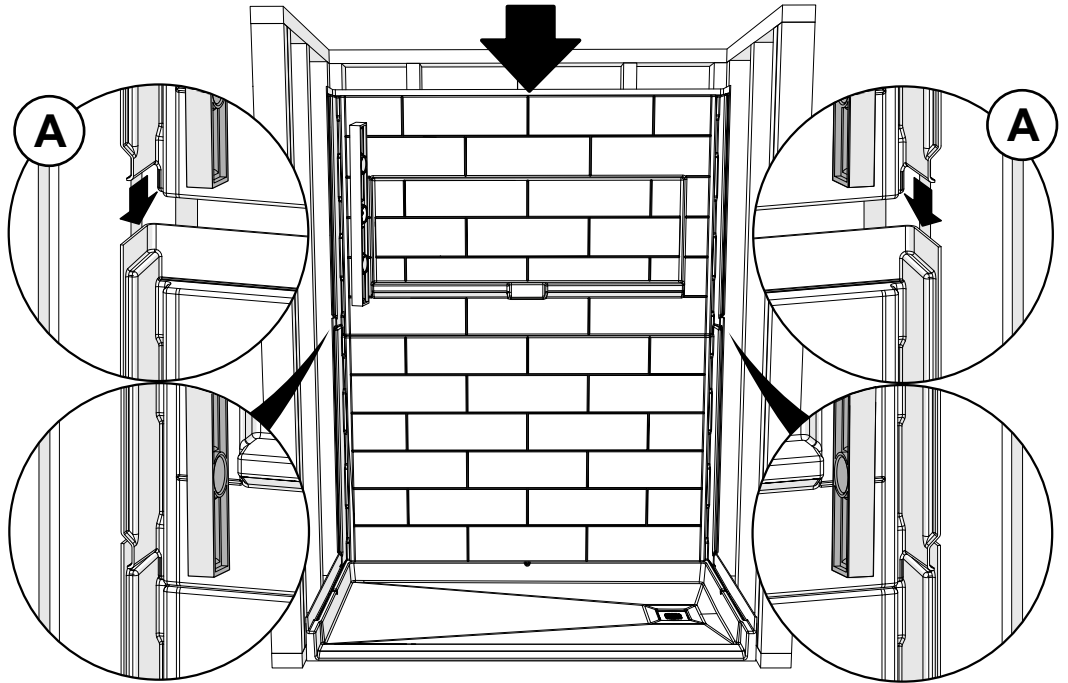

B. Add shims as needed. Drill the flange and screw with the screws and a screwdriver, 3/8" from the top of the flange. Cut shim excess.

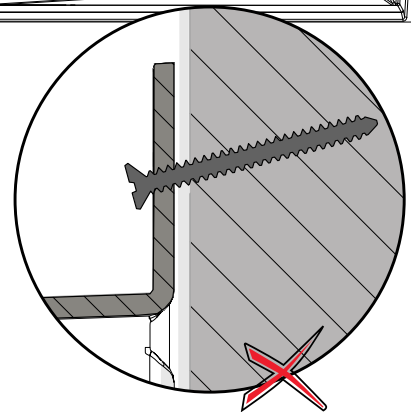
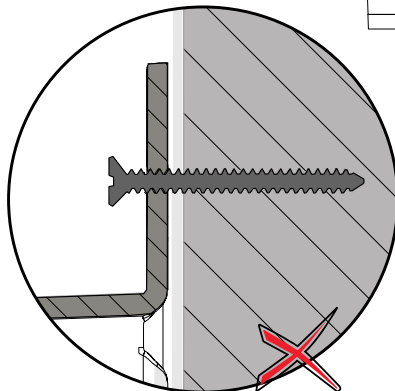
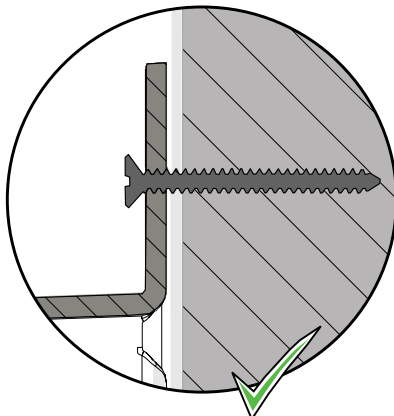
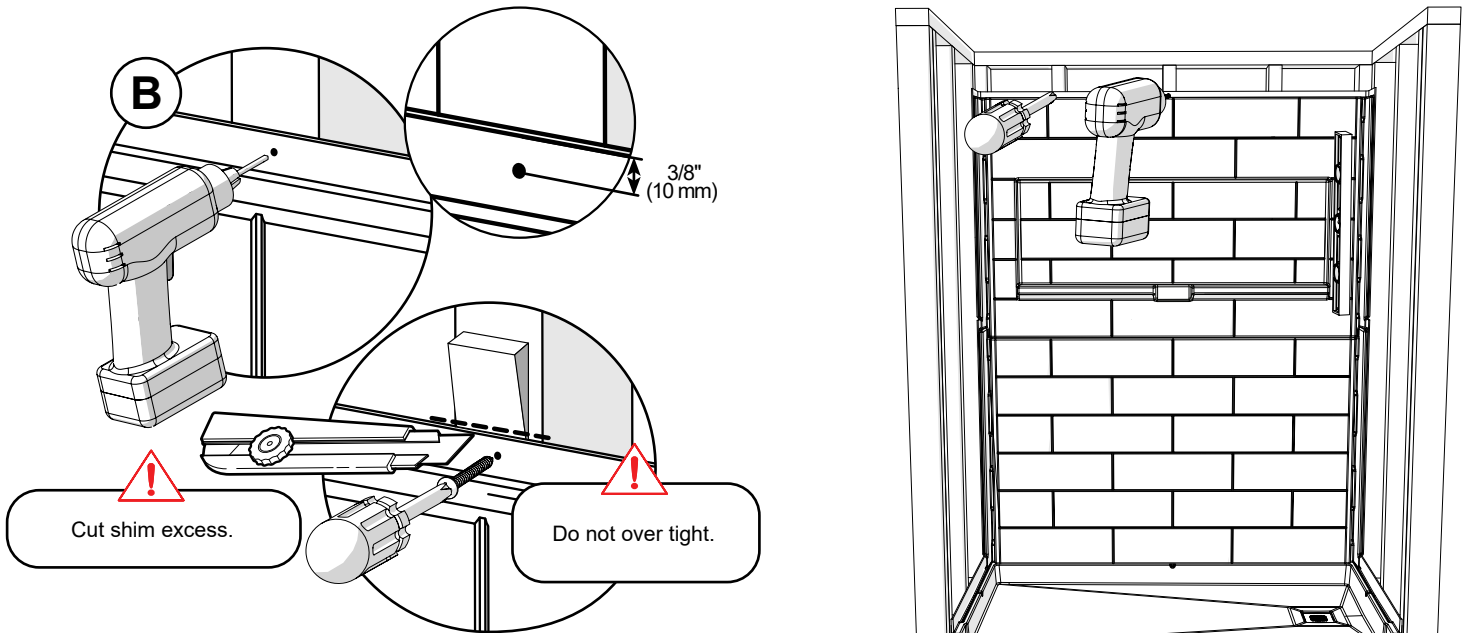

5

A. Use a wood block or stud on each side to secure the upper back wall (#3) to the lower back wall (#2). Drill the flanges and screw with the screws and a screwdriver.

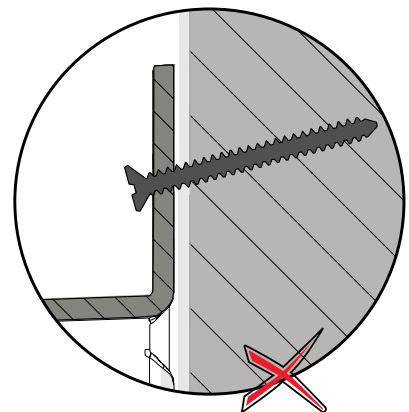
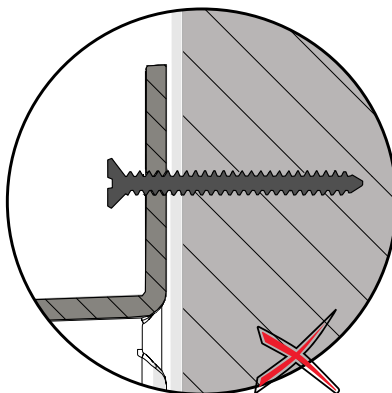
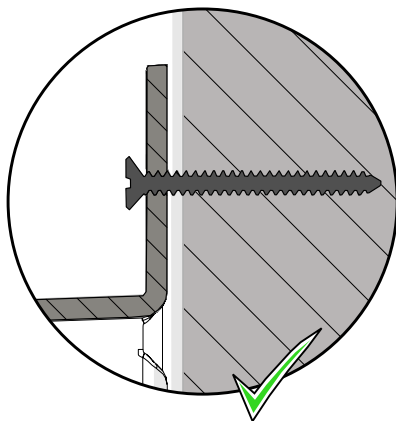
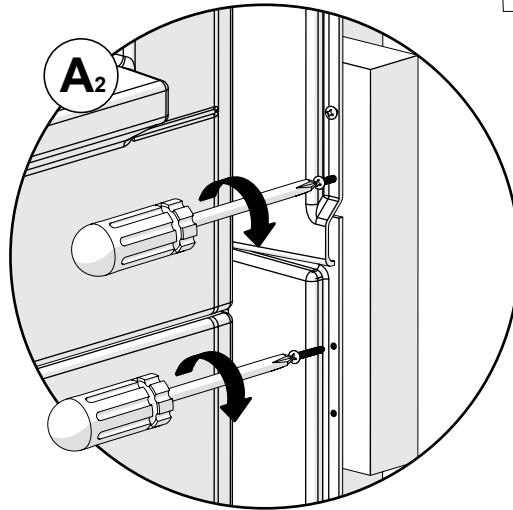
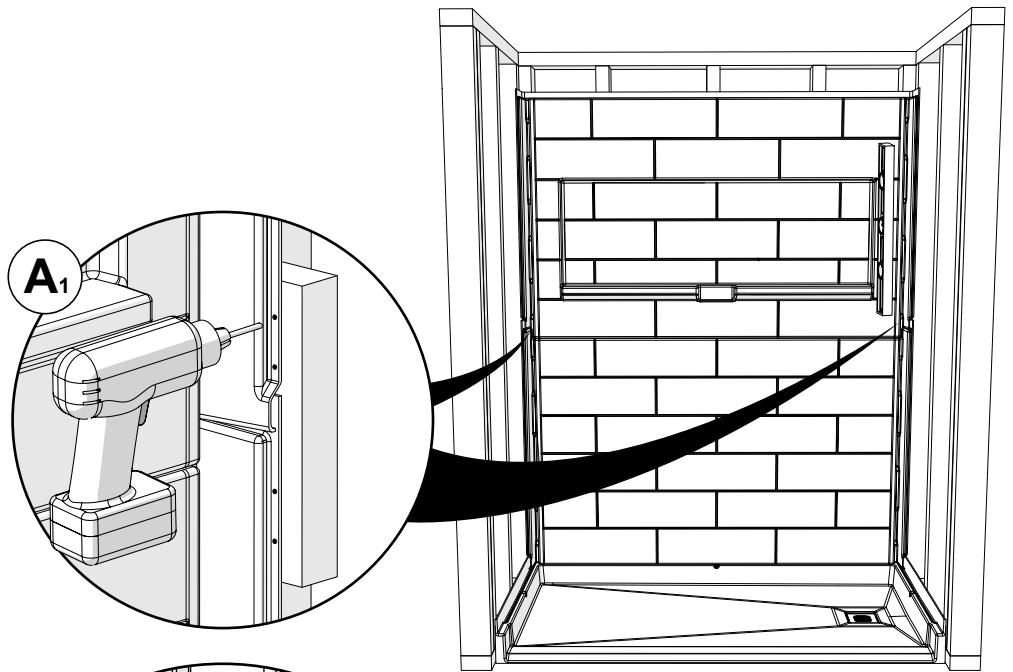

6



Make sure the rim of the base is clean.

A. Temporarily dry fit the side walls (#4) and (#5) pushing back into the back wall channel.

B. Verify all walls are level and fit properly. Side walls should be aligned with the front of the base. If adjustment is required, correct the fit with wood shims on the back flange of the base or the back wall depending on the situation.

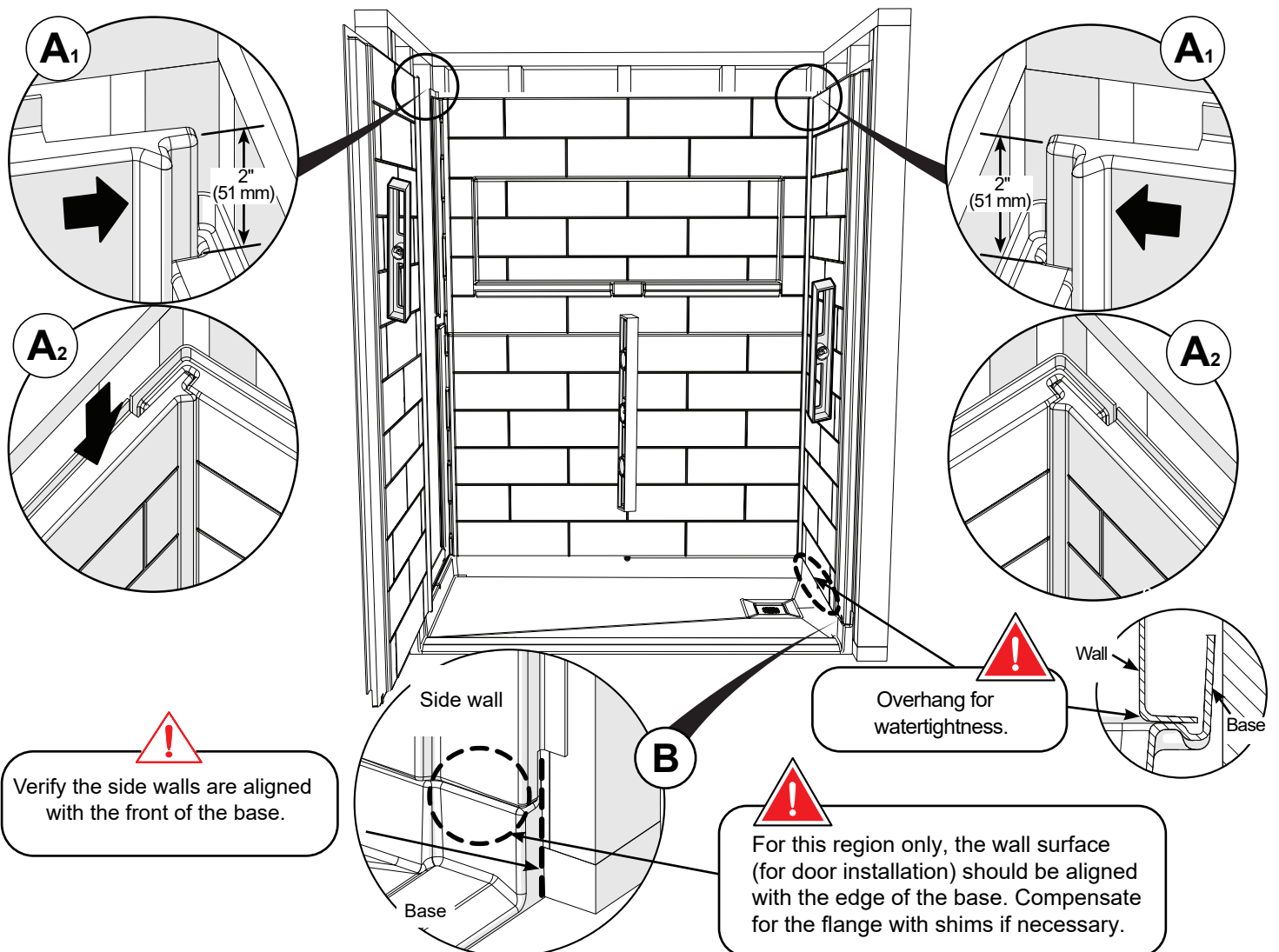

Remove the side wall from the valve side of the shower



7

A. Pre-drill the walls for faucets. Measure the distance between the front face of the back wall to the center of the faucet. Then measure the distance from the top of the base deck to the center of the faucet.

B. Using those two measurements, mark the position of the faucet hole on the remaining side wall. Measure from the side and bottom of the shower. Repeat this process for all required faucet holes.

C. Drill a hole from tiled side for the faucets at the previously marked positions. Pre-drill the hole with the 1/8" drill bit. The hole saw size is determined by the faucet type. Refer to the faucet installation manual for hole saw size.

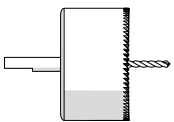
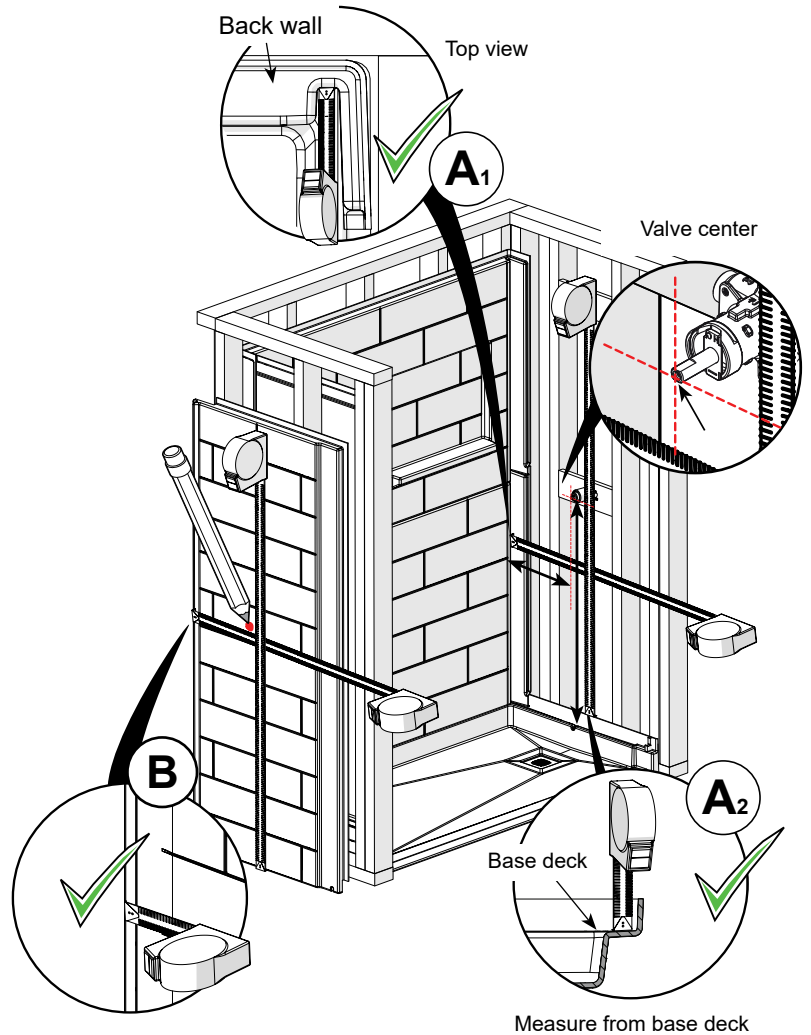

Hole saws can be rented at your local hardware store or any tool rental location.



For safe hole saw usage always pre-drill a hole and wear safety glasses when drilling.

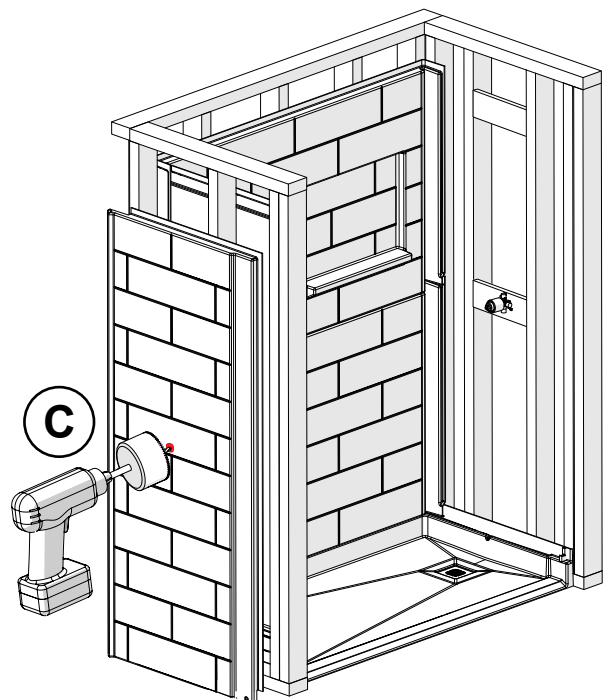

8



Make sure the rim of the base is clean.

A. Using 100% silicone, caulk interior channel of side wall vertical seam. On the shower base, apply silicone caulking to the flat surface absent the drain trough at the front edge of the base to prevent water migration outside the shower enclosure. Surface caulking is optional and not required.

B. Insert the side wall (#5) inside the channel on the back wall in two movements: While lifting 2" above the base fully insert inside the lower channel, then lower until the side wall is in full contact with the base.

C. Verify wall is level and fit properly. Side walls should be aligned with the front of the base. If adjustment is required, correct with wood shims on the back flange of the base or the back wall depending on the situation.

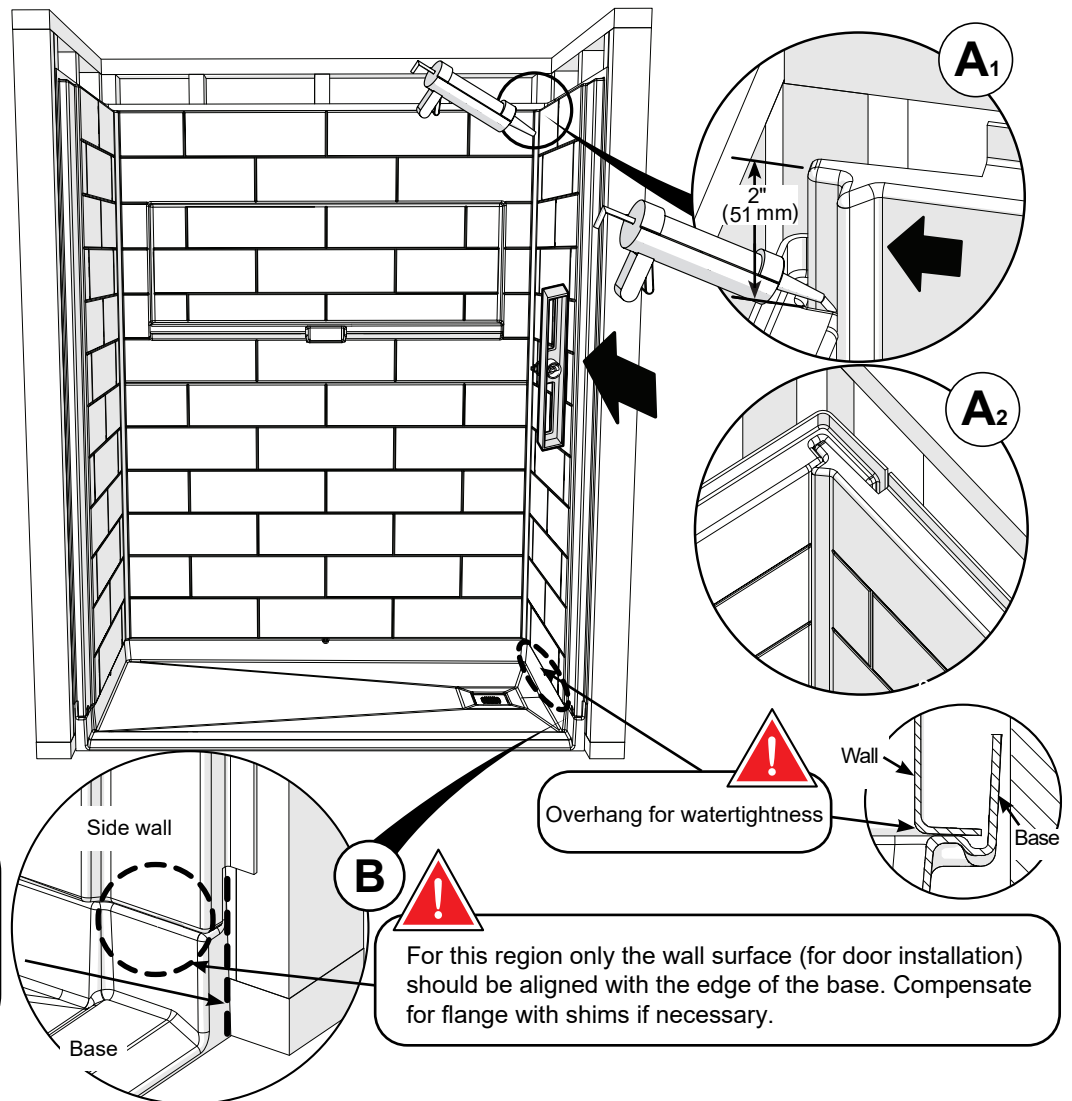

Verify the side walls are aligned with the front of the base.

For this region only the wall surface (for door installation) should be aligned with the edge of the base. Compensate for flange with shims if necessary.

9

A. Add shims as needed. Drill the flange and screw with the screws and a screwdriver. Cut shim excess.

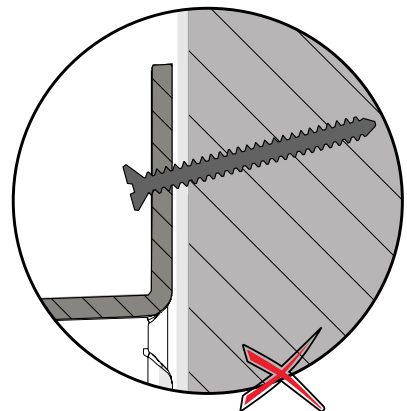
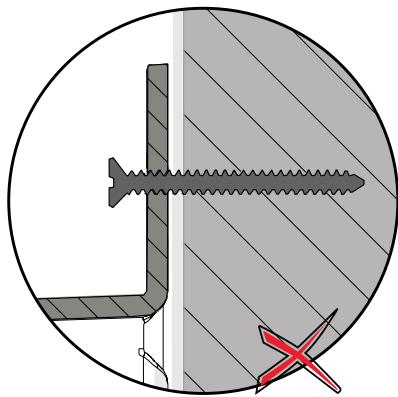
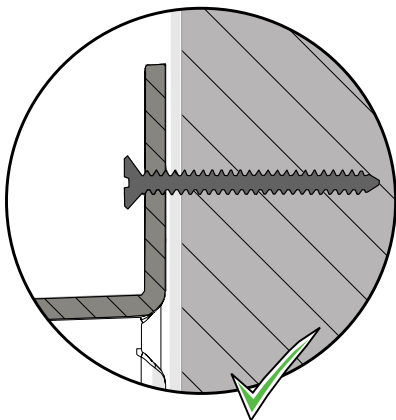
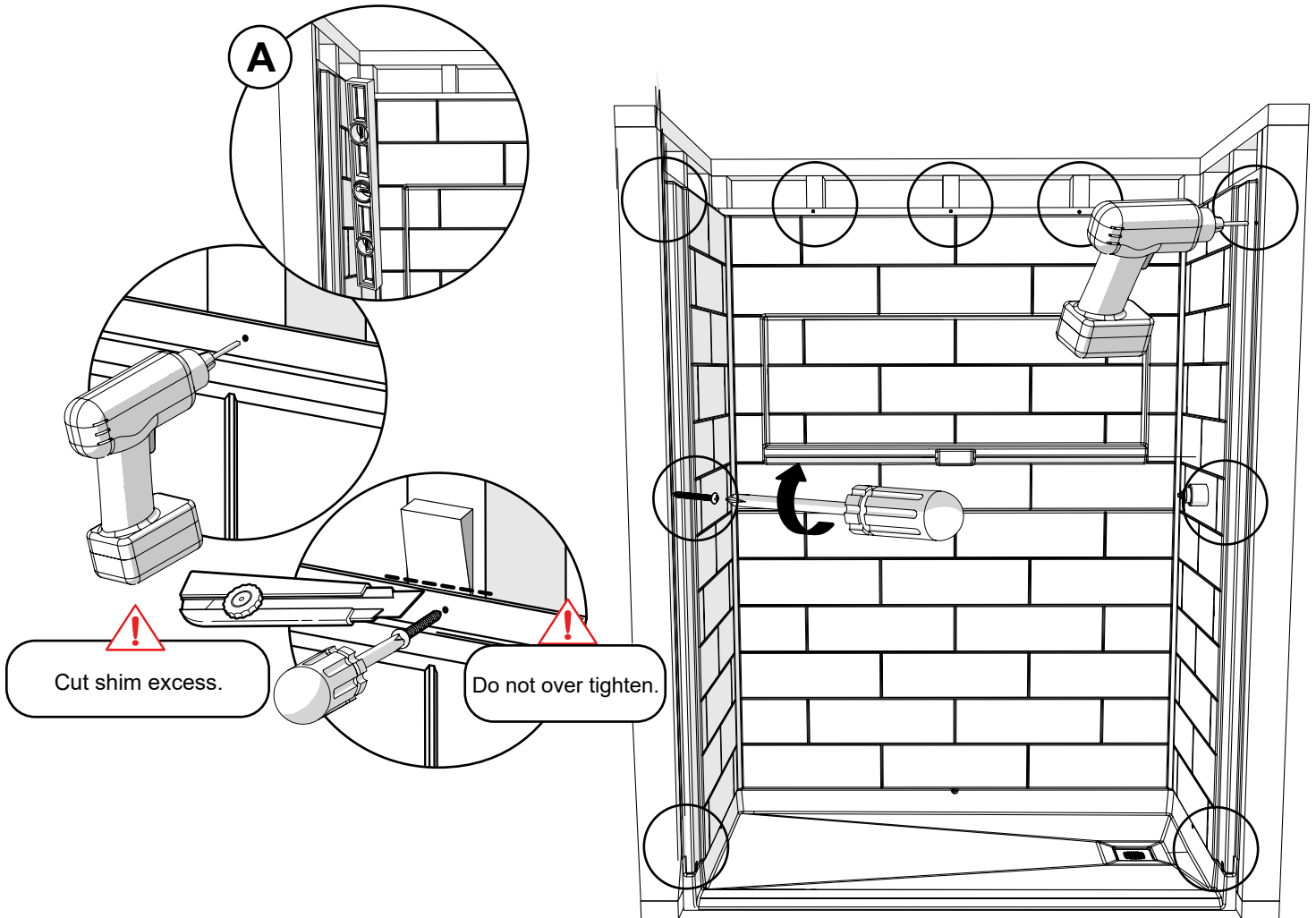

10

A. Exterior caulking of the seams is optional, done at owners preference. If you want to apply caulking to these seams, follow instructions below.

Quick tip 

Apply masking tape on both sides of the joint where you will run a bead of silicone. Apply the silicone, smooth with a wet finger then remove the masking tape.

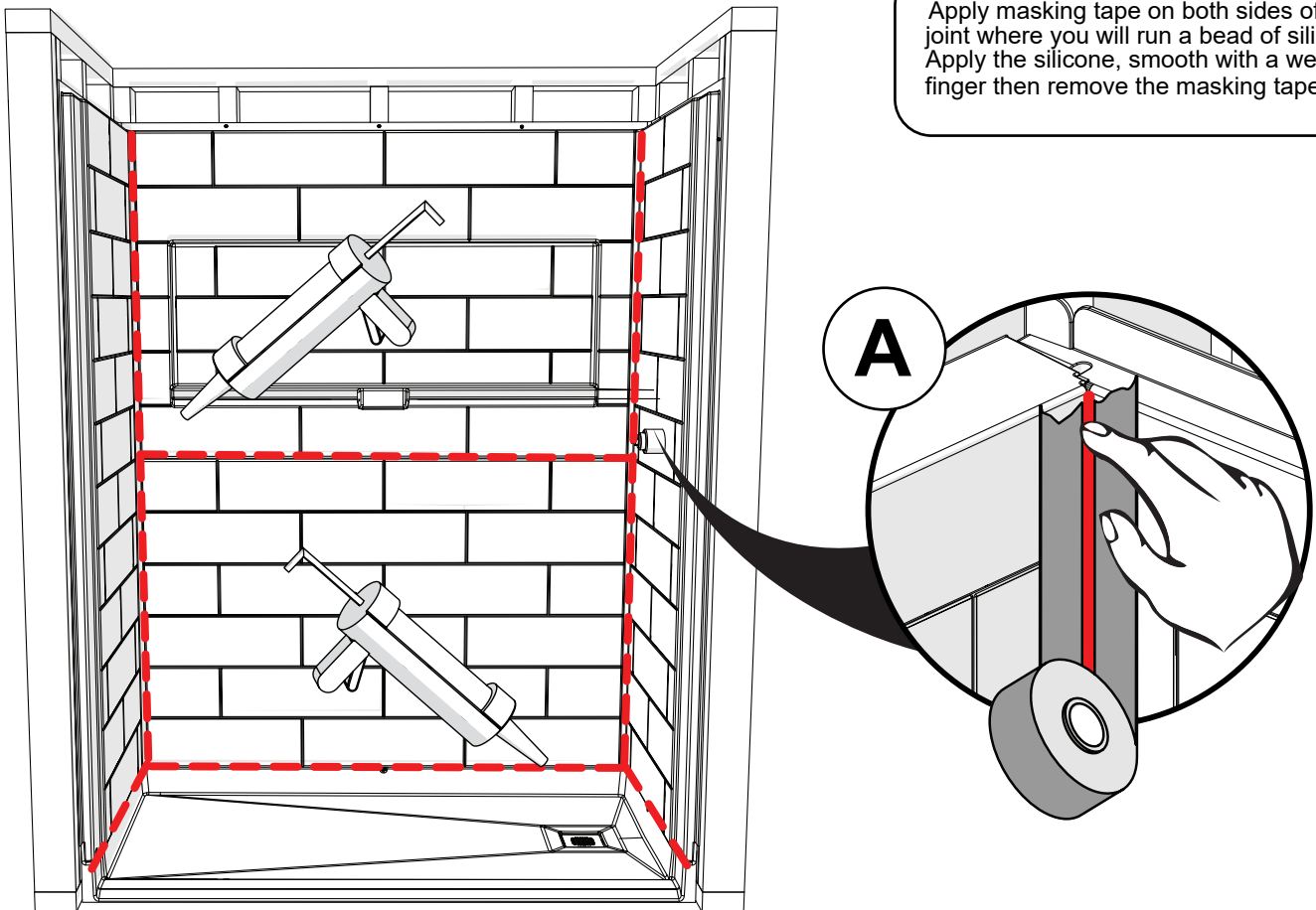

All faucets installed on the walls must be sealed with silicone.

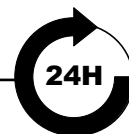

Wait 24 hours before using the shower.

11

A. Make cutout in upper back panel if a window is present.
MEASURE CUTOUT CAREFULLY. CUTOUT PIECE MAY BE USED AS FILLER AROUND THE WINDOW. FINISH AS PREFERRED, OR PURCHASE AVAILABLE 3" FLANGE TRIM KIT.



Measure window opening size minus window trim.

Remove all window trim.



CAREFULLY measure and mark window cutout on the upper back wall panel.

Make the cutout.

Cutout may be used for side filler pieces. DO NOT Discard.

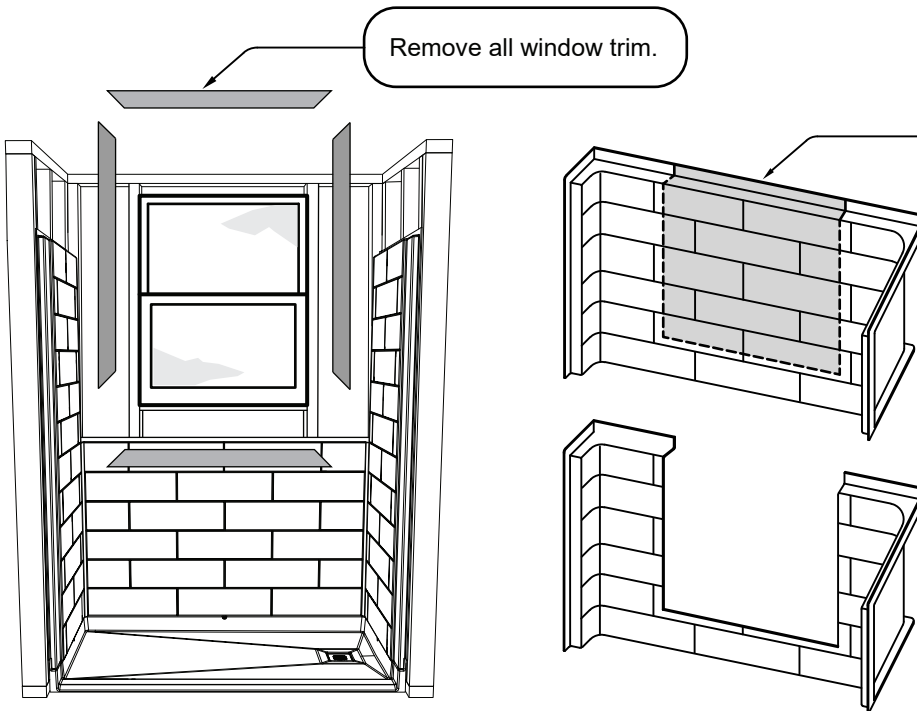

NOTE: PVC trim boards are readily available for purchase at your local home center.

Trial fit upper panel around the window. Adjust if necessary. When satisfied with fit, install water resistant trim around the window. Caulk all window seams and joints.

Maintenance tips

Follow these general use and maintenance tips, as well as any that come with the products and you will be rewarded with years of great service.

- ☒ Clean regularly with a non-abrasive cleaning spray or cream based cleansing agent.
- ☒ Never use tile or grout cleaner as they are not adequate for these products and could damage the unit.
- ☒ Never use abrasive cleansers, scrapers, metal brushes or anything that could scratch or dull the surface of your unit.
- ☒ In order to avoid damaging the finish of the unit when renovating, remove plaster residues from surfaces with a plastic or wooden spatula wrapped in a moist cloth.
- ☒ Wipe down your shower door after every use with a squeegee or soft cloth. This reduces the buildup from soap, bath additives, natural body oils and mineral deposits in water, making cleaning easy and helping to maintain the unit's natural luster.



USEFUL LINKS

LINK to Inspire Shower Installation video: <https://youtu.be/IXIYrixNNol>

LINK to Collapsible Water Retainer Installation video: <https://youtu.be/1LNQjWteJcw>

LIMITED WARRANTY

For warranty inquiries call: 877-947-7769



WWW.FREEDOMSHOWERS.COM

T. 1-877-947-7769