

Freedom Easy Step Shower Pan 60" x 31" Left or Right Drain

MODEL: APF6030SHPAN LR



Left Drain Option Shown



Made in USA



30-Year Warranty

EXTERIOR DIMENSIONS:

60" x 31" x 6"

FEATURES:

- 4" easy step threshold
- Pre-leveled and reinforced shower base for easy installation
- Handed by drain, Left or Right available
- Fiberglass construction
- Durable, easy-to-clean applied acrylic
- Textured Floor

ACCESSORY PACKAGES AVAILABLE:

Residential Safety Package includes:

- Grab bars x 3
- Wall-mounted, folding shower seat

INDIVIDUAL ACCESSORIES AVAILABLE:

- Fold-up shower bench (various styles)
- Grab bars (various styles and sizes)
- Adjustable handheld shower kit with bar
- ADA pressure-balanced shower valve
- Weighted shower curtain and rod
- Drain and chrome strainer
- Flange trim kit

For complete shower unit with walls see
APF6030SH5P LR

Freedom Accessible Shower Pan 60" x 31" Left or Right Drain

MODEL: APF6030SHPAN LR

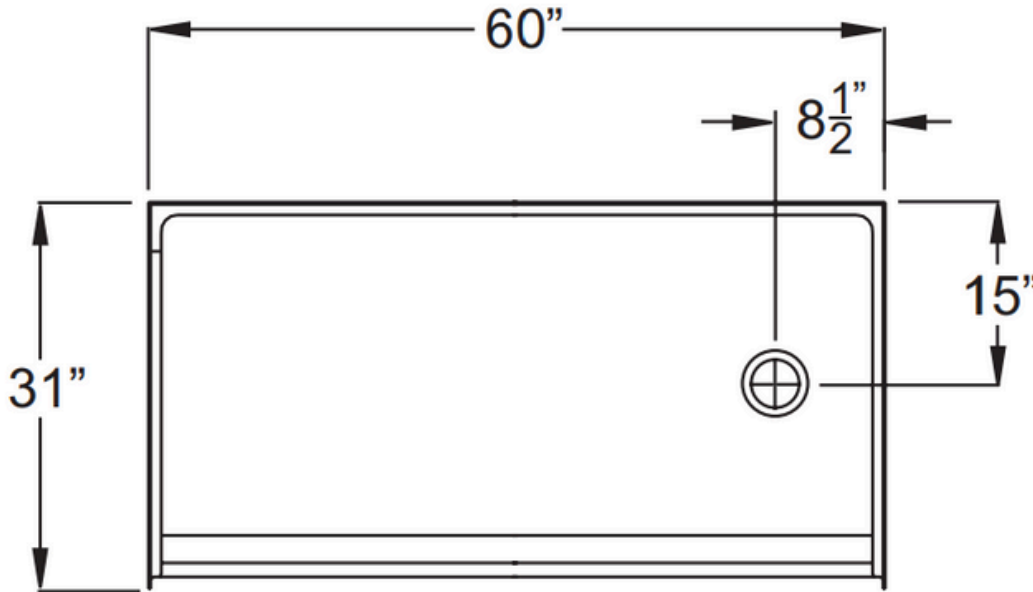

TOP VIEW

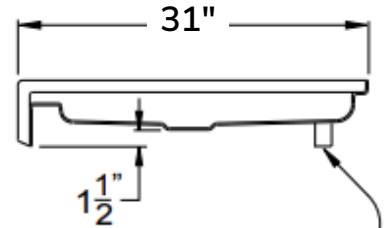

Wood Base With Leveling Leg.

Wood Bottom With Leveling Leg will have the base level as it sits on the floor.

SIDE VIEW

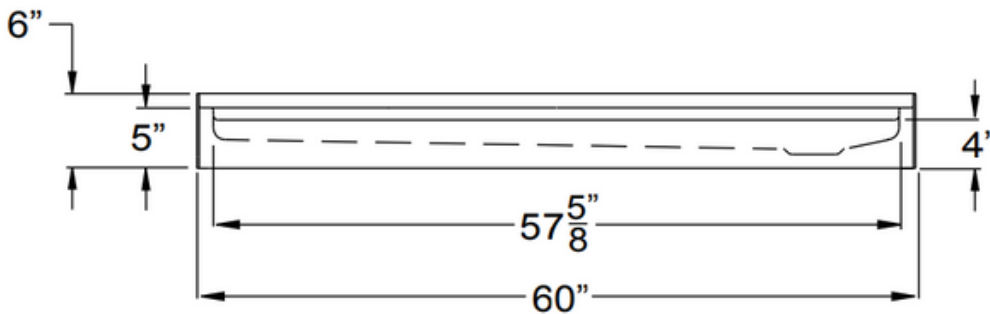

FRONT VIEW

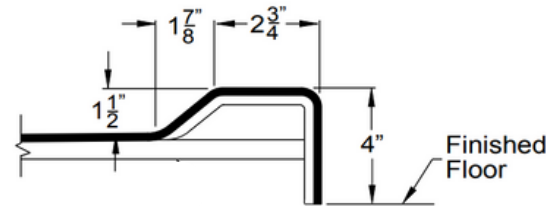

THRESHOLD VIEW

NOTES:

Dimensional Tolerance $\pm 1/2"$.
Accessibility Professionals Inc. assumes
no responsibility for prep work

CODE COMPLIANCE:

- IPC International Plumbing Code
- UPC Uniform Plumbing Code
- ANSI Z124.2 Standards for Plastic Showers
- CSA Canadian Standards Association

FRAME-IN DIMENSIONS:

A	60 1/4"
B	8 5/8"
C	31"
D	15"

