

Freedom Accessible Shower Pan 60" x 31" Center Drain

MODEL: APF6030BFPANC



Made in USA



30-Year Warranty

EXTERIOR DIMENSIONS:

60" x 31" x 4 1/4"

FEATURES:

- 3/4" barrier free threshold
- Pre-leveled and reinforced shower base for easy installation
- Center drain
- Fiberglass construction
- Durable, easy-to-clean applied acrylic
- Textured Floor

ACCESSORY PACKAGES AVAILABLE:

Residential Safety Package includes:

- Grab bars x 3
- Wall-mounted, folding shower seat

Water Retention Package includes:

- Collapsible water retainer with end caps
- Weighted shower curtain
- Curtain rod

INDIVIDUAL ACCESSORIES AVAILABLE:

- Fold-up shower bench (various styles)
- Grab bars (various styles and sizes)
- Adjustable handheld shower kit with bar
- ADA pressure-balanced shower valve
- Collapsible water retainer with end caps
- Weighted shower curtain and rod
- Drain and chrome strainer
- Flange trim kit

For complete shower unit with pan and walls see model APF6030BF5PC

Freedom Accessible Shower Pan 60" x 31" Center Drain

MODEL: APF6030BFPANC

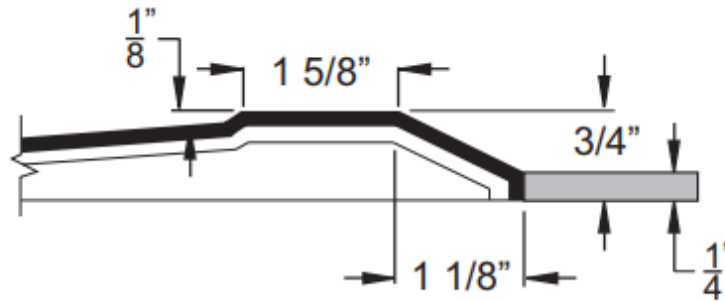
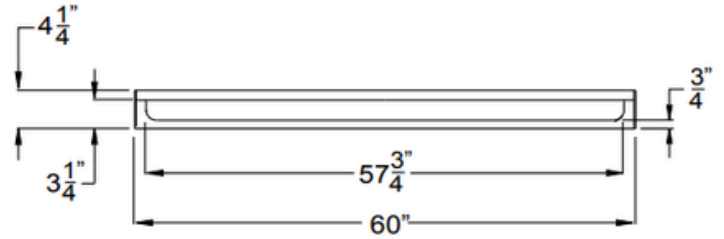
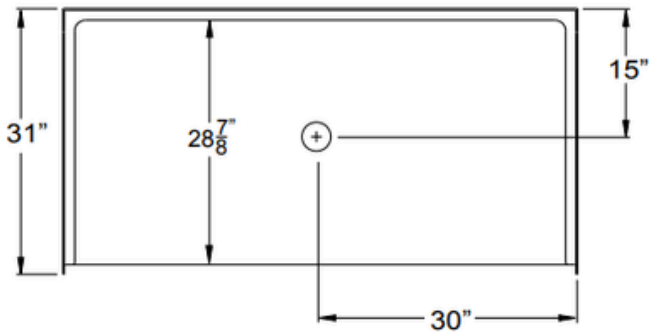

THRESHOLD VIEW

NOTES:

Dimensional Tolerance $\pm 1/2"$.
Accessibility Professionals Inc.
assumes no responsibility for prep work

CODE COMPLIANCE:

- ANSI Z124.2 Standards for Plastic Showers
- CSA Canadian Standards Association

FRAME-IN DIMENSIONS:

A	60 1/4"
B	30 1/8"
C	31"
D	15"

