

Freedom Accessible Corner Shower Pan 50" x 50"

MODEL: APF5050BFPANDE



Made in USA



30-Year Warranty

EXTERIOR DIMENSIONS:

50" x 50" x 4 1/2"

FEATURES:

- Corner Shower Pan
- 1" barrier free threshold on two sides
- Pre-leveled and reinforced shower base for easy installation
- Center drain
- Fiberglass construction
- Durable, easy-to-clean applied acrylic
- Textured Floor

ACCESSORY PACKAGES AVAILABLE:

Residential Safety Package includes:

- Grab bars x 3
- Wall-mounted, folding shower seat

Handheld and Valve package includes:

- Adjustable handheld shower kit with bar
- ADA pressure-balanced shower valve

INDIVIDUAL ACCESSORIES AVAILABLE:

- Fold-up shower bench (various styles)
- Grab bars (various styles and sizes)
- Adjustable handheld shower kit with bar
- ADA pressure-balanced shower valve
- 10' Collapsible water retainer with end caps
- Corner curtain rod with J hook
- Weighted shower curtains x 2
- Drain and chrome strainer
- Flange trim kit

Freedom Accessible Corner Shower Pan 50" x 50"

MODEL: APF5050BFPANDE

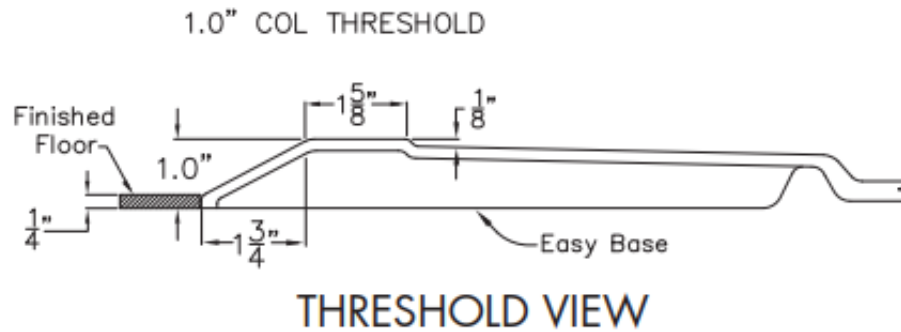
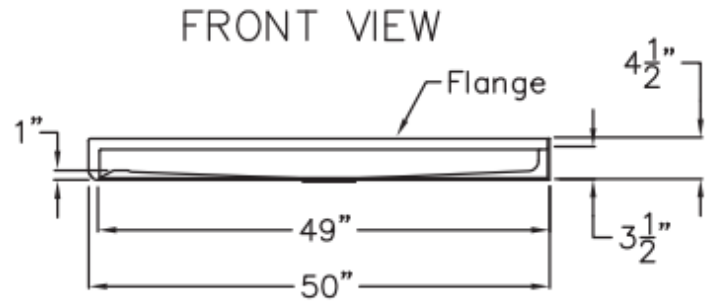
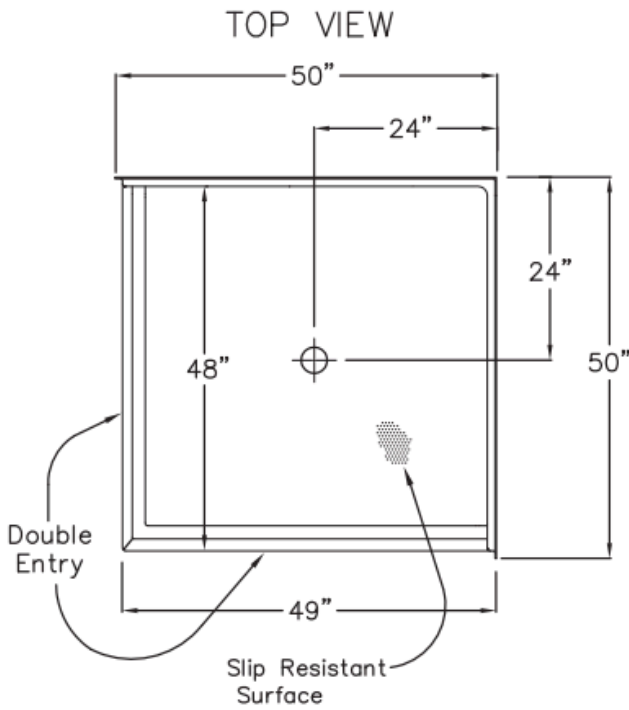

NOTES:

Dimensional Tolerance $\pm 1/2"$.
 Accessibility Professionals Inc.
 assumes no responsibility for prep work

CODE COMPLIANCE:

- IPC International Plumbing Code
- UPC Uniform Plumbing Code
- ANSI Z124.2 Standards for Plastic Showers
- CSA Canadian Standards Association

FRAME-IN DIMENSIONS:

A	50"
B	24"
C	50"
D	24"

