

# Freedom Accessible Shower Pan 50" x 50" Center Drain

MODEL: APF5050BFPAN



Made in USA



30-Year Warranty

## EXTERIOR DIMENSIONS:

50 1/2" x 50 1/8" x 4 1/2"

## INTERIOR DIMENSIONS:

48" x 48"

## FEATURES:

- Interior dimension meets Veterans Affairs code requirements
- 1" Barrier Free threshold
- Pre-leveled and reinforced shower base for easy installation
- Center drain
- Fiberglass construction
- Durable, easy-to-clean applied acrylic
- Textured Floor

## ACCESSORY PACKAGES AVAILABLE:

Residential Safety Package includes:

- Grab bars x 3
- Wall-mounted, folding shower seat

Water Retention Package includes:

- Collapsible water retainer with end caps
- Weighted shower curtain
- Curtain rod

## INDIVIDUAL ACCESSORIES AVAILABLE:

- Fold-up shower bench (various styles)
- Grab bars (various styles and sizes)
- Adjustable handheld shower kit with bar
- ADA pressure-balanced shower valve
- Collapsible water retainer with end caps
- Weighted shower curtain and rod
- Drain and chrome strainer
- Flange trim kit

For complete shower unit with pan and walls see model APF5050BF5P

# Freedom Accessible Shower Pan 50" x 50" Center Drain

MODEL: APF5050BFPAN

TOP VIEW

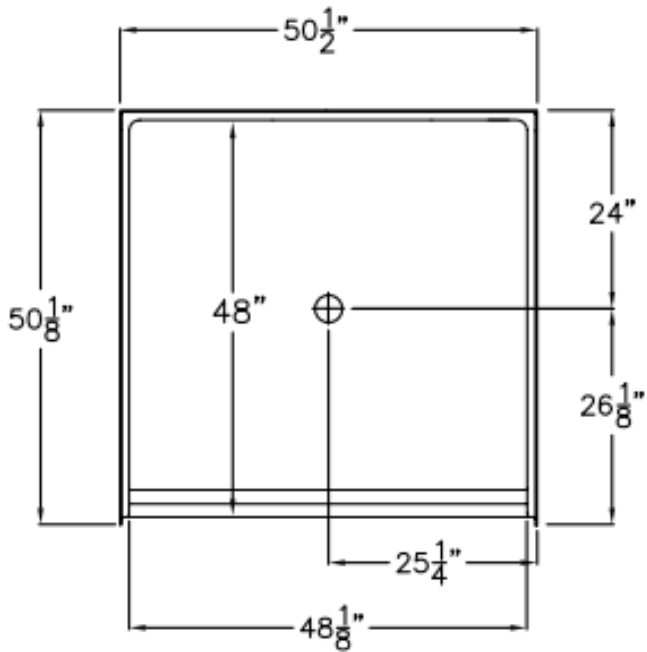

SIDE VIEW

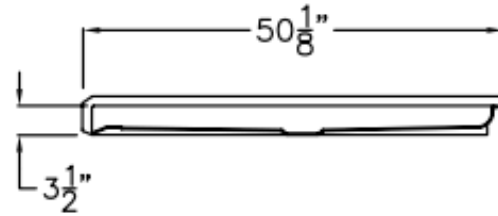

FRONT VIEW

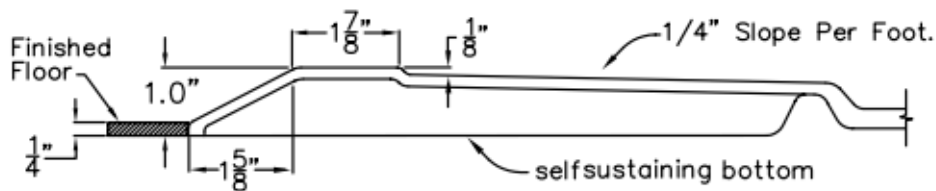
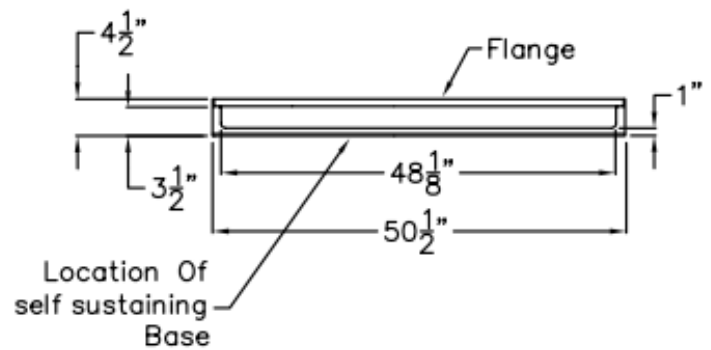

THRESHOLD VIEW

**NOTES:**

Dimensional Tolerance  $\pm 1/2"$ .  
Accessibility Professionals Inc.  
assumes no responsibility for prep work

**CODE COMPLIANCE:**

- IPC International Plumbing Code
- UPC Uniform Plumbing Code
- ANSI Z124.2 Standards for Plastic Showers
- CSA Canadian Standards Association

**FRAME-IN DIMENSIONS:**

A	50 3/4"
B	25 3/8"
C	50 1/8"
D	24"

