

Freedom Accessible Shower 60" x 33 3/8" Left or Right Drain

MODEL: APF6033BF5P LR



Left Drain Shower Shown



Made in USA



30-Year Warranty

EXTERIOR DIMENSIONS:

60" x 33 3/8" x 78"

FEATURES:

- 5-piece for remodeling
- 1" barrier free threshold with pre-leveled and reinforced shower base for easy installation
- Left or right drain for bathtub replacement
- Molded soap ledge
- Durable, easy-to-clean applied acrylic with 8" tile pattern
- Fully reinforced walls that offers strength and ease of installation for accessories

ACCESSORY PACKAGES AVAILABLE:

Residential Safety Package includes:

- Fold-up wall-mounted shower bench
- 3 x Grab bars

Water Retention Package includes:

- Collapsible water retainer with end caps
- Weighted shower curtain and rod

INDIVIDUAL ACCESSORIES AVAILABLE:

- Fold-up shower bench (various styles)
- Grab bars (various styles and sizes)
- Adjustable handheld shower kit with bar
- ADA pressure-balanced shower valve
- Collapsible water retainer with end caps
- Weighted shower curtain and rod
- Drain and chrome strainer
- Flange trim kit

Freedom Accessible Shower 60" x 33 3/8" Left or Right Drain

MODEL: APF6033BF5P LR

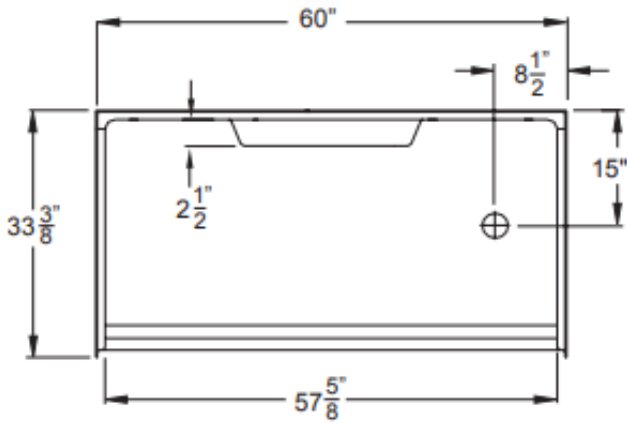

Right Drain Shown

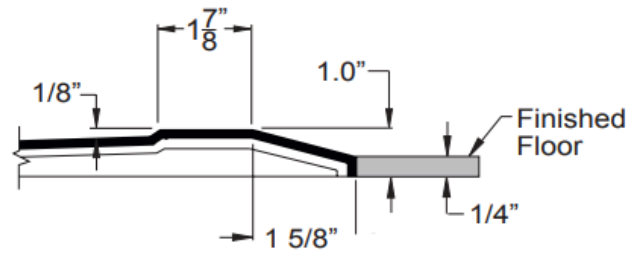

THRESHOLD VIEW

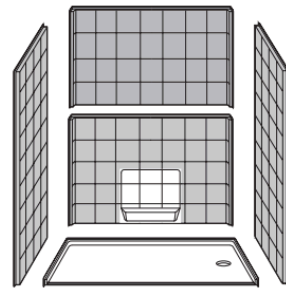
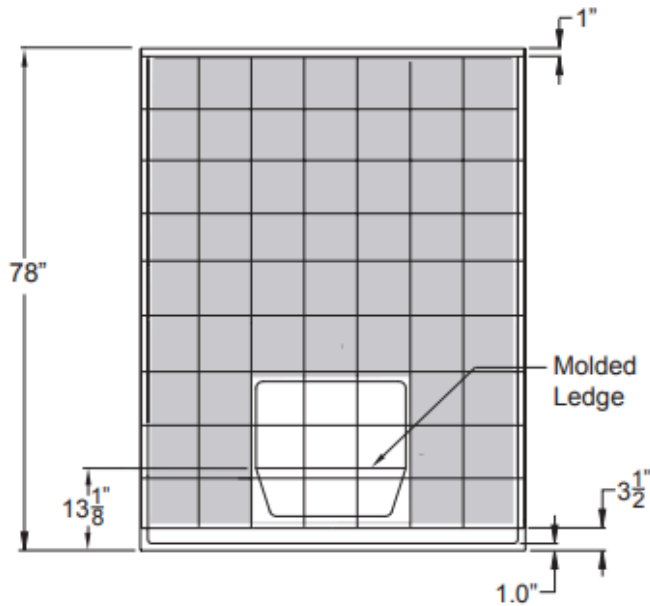

Right Drain Shown

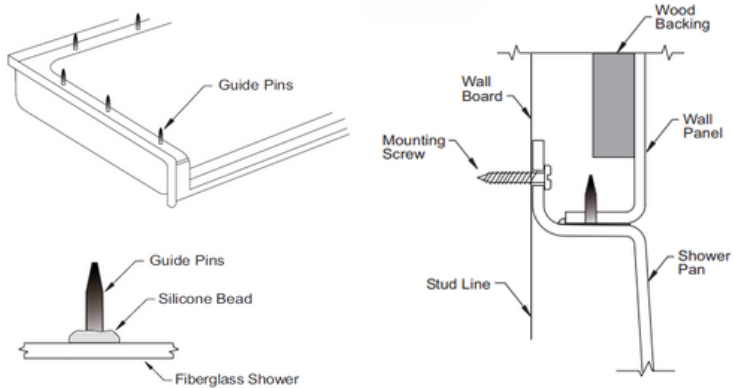

NOTES:

Dimensional Tolerance $\pm 1/2"$.
Accessibility Professionals Inc.
assumes no responsibility for prep work

CODE COMPLIANCE:

- IPC International Plumbing Code
- UPC Uniform Plumbing Code
- ANSI Z124.2 Standards for Plastic Showers
- CSA Canadian Standards Association

FRAME-IN DIMENSIONS:

A	60 1/4"
B	8 5/8"
C	33 3/8"
D	15"

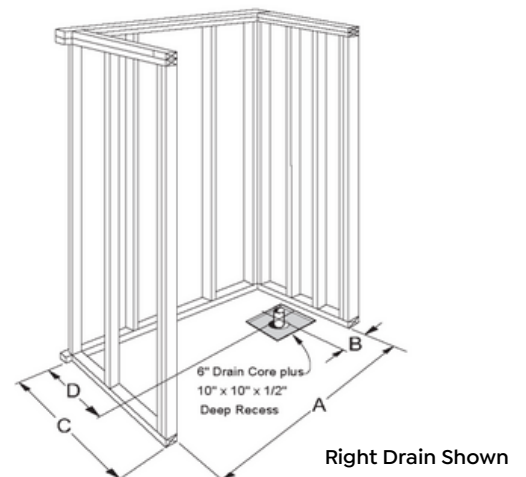

Right Drain Shown