

Freedom Accessible Shower Pan Inspire Series 60" x 32" Left or Right Drain

MODEL: APX6032BFP LR



Left Drain Shown



Made in USA



30-Year Warranty

EXTERIOR DIMENSIONS:

60" x 32" x 6"

INTERIOR DIMENSIONS:

57" x 26 5/8"

FEATURES:

- 7/8" barrier free threshold
- Left or right drain location, ideal for bathtub replacement
- Underside of pan is smooth and pre-levell'd for easy installation
- Fiberglass construction
- Applied acrylic finish
- Textured slip-resistant floor
- Drain included, square chrome plate, no caulk
- Works with all wall materials and finishes
- Adaptable for shower doors
- Consistent nailing flange

ACCESSORY PACKAGES AVAILABLE:

Residential Safety Package includes:

- Fold-up wall-mounted shower bench
- 3 x Grab bars

Water Retention Package includes:

- Collapsible water retainer with end caps
- Weighted shower curtain and rod

INDIVIDUAL ACCESSORIES AVAILABLE:

- Fold-up shower bench (various styles)
- Grab bars (various styles and sizes)
- Adjustable handheld shower kit with bar
- ADA pressure-balanced shower valve
- Collapsible water retainer with end caps
- Weighted shower curtain and rod

Freedom Accessible Shower Pan Inspire Series 60" x 32"

MODEL: APX6032BFP LR

FRONT VIEW

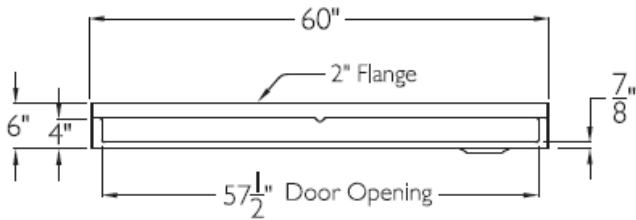

Right Drain Shown

TOP VIEW

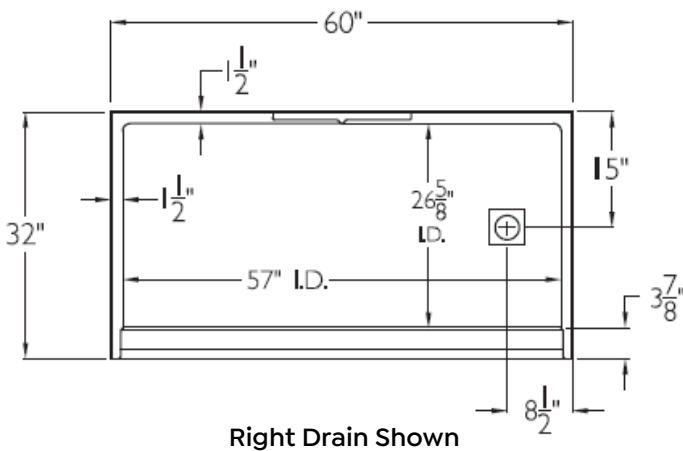

Right Drain Shown

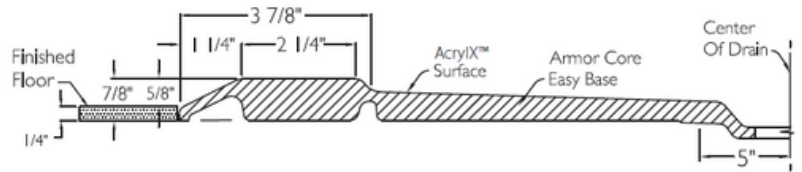

COMES WITH NO CAULK DRAIN and Square Strainer Plate
Cutaway Drain Detail

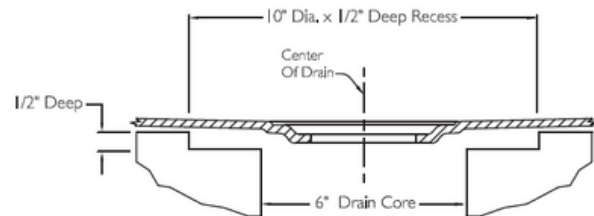

NOTES:

Dimensional Tolerance $\pm 1/2"$.
Accessibility Professionals Inc.
assumes no responsibility for prep work

CODE COMPLIANCE:

- IPC International Plumbing Code
- UPC Uniform Plumbing Code
- ANSI Z124.2 Standards for Plastic Showers
- CSA Canadian Standards Association
- NFPA 101.24.2.8

FRAME-IN DIMENSIONS:

A	60 1/4"
B	8 9/16"
C	32"
D	15"

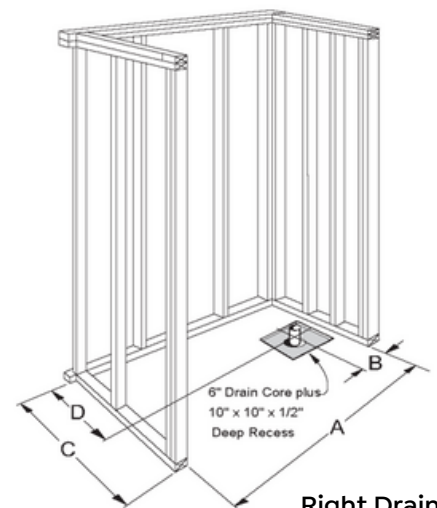

Right Drain Shown